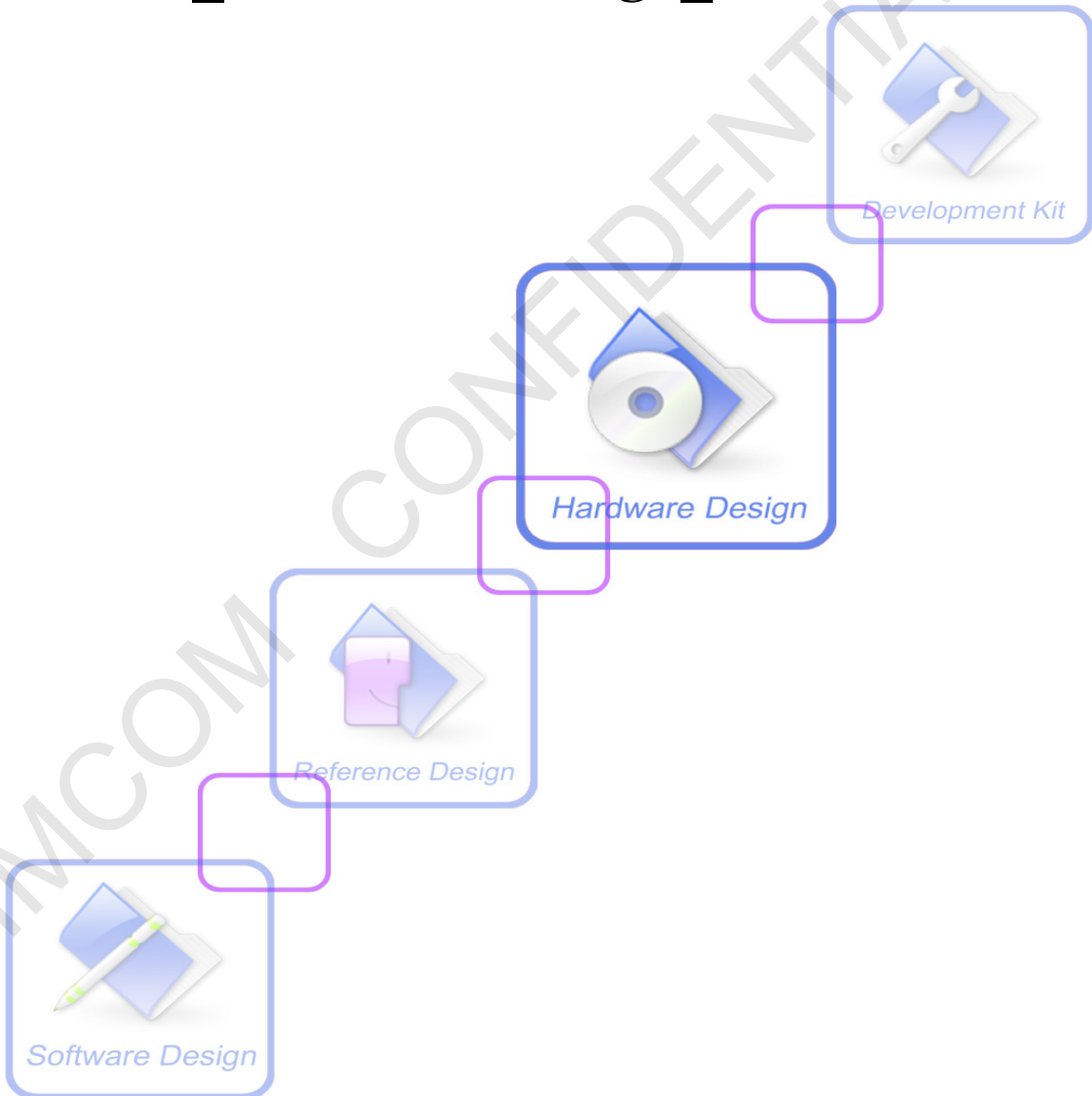




A company of SIM Tech

## SIM800H\_Hardware Design\_V2.03



<b>Document Title</b>	SIM800H_Hardware Design_V2.03
<b>Version</b>	V2.03
<b>Date</b>	2016-10-10
<b>Status</b>	Release
<b>Document Control ID</b>	SIM800H_Hardware Design_V2.03

### General Notes

SIMCom offers this information as a service to its customers, to support application and engineering efforts that use the products designed by SIMCom. The information provided is based upon requirements specifically provided to SIMCom by the customers. SIMCom has not undertaken any independent search for additional relevant information, including any information that may be in the customer's possession. Furthermore, system validation of this product designed by SIMCom within a larger electronic system remains the responsibility of the customer or the customer's system integrator. All specifications supplied herein are subject to change.

### Copyright

This document contains proprietary technical information which is the property of SIMCom Limited, copying of this document and giving it to others and the using or communication of the contents thereof, are forbidden without express authority. Offenders are liable to the payment of damages. All rights reserved in the event of grant of a patent or the registration of a utility model or design. All specification supplied herein are subject to change without notice at any time.

*Copyright © Shanghai SIMCom Wireless Solutions Ltd. 2016*

## Contents

<b>Table Index .....</b>	<b>6</b>
<b>Figure Index .....</b>	<b>8</b>
<b>Version History .....</b>	<b>10</b>
<b>1. Introduction.....</b>	<b>11</b>
<b>2. SIM800H Overview .....</b>	<b>11</b>
2.1. SIM800H.....	11
2.2. SIM800H Key Features .....	11
2.3. Operating Mode .....	13
2.4. Functional Diagram.....	14
<b>3. Package Information .....</b>	<b>15</b>
3.1. Pin Out Diagram .....	15
3.2. Pin Description.....	16
3.3. Package Dimensions .....	18
<b>4. Application Interface.....</b>	<b>20</b>
4.1. Power Supply .....	20
4.1.1. Power Supply Pin.....	21
4.1.2. Monitoring Power Supply .....	22
4.2. Power on/off Scenarios .....	22
4.2.1. Power on SIM800H.....	22
4.2.2. Power down SIM800H.....	23
4.2.3. Reset Function.....	24
4.3. Power Saving Mode .....	25
4.3.1. Minimum Functionality Mode .....	26
4.3.2. Sleep Mode 1 (AT+CSCLK=1) .....	26
4.3.3. Wake Up SIM800H from Sleep Mode 1.....	26
4.3.4. Sleep Mode 2 (AT+CSCLK=2) .....	26
4.3.5. Wake Up SIM800H from Sleep Mode 2.....	27
4.4. RTC Backup.....	27
4.5. Serial Port and USB Interface .....	28
4.5.1. Function of Serial Port .....	28
4.5.2. Serial Interfaces.....	29
4.5.3. Debug Interface.....	31
4.5.4. Software Upgrade.....	32
4.6. RI Behaviors .....	32
4.7. Audio Interfaces .....	33

4.7.1.	Speaker Interfaces Configuration.....	34
4.7.2.	Microphone Interfaces Configuration.....	35
4.7.3.	Audio Electronic Characteristic.....	35
4.7.4.	TDD.....	35
4.8.	SIM Card Interface.....	36
4.8.1.	SIM Card Application.....	36
4.8.2.	SIM Card Design Guide.....	37
4.8.3.	Design Considerations for SIM Card Holder.....	37
4.9.	PCM Interface.....	39
4.9.1.	PCM reference circuit.....	40
4.10.	Keypad Interface.....	41
4.11.	I2C Bus.....	43
4.12.	General Purpose Input/Output (GPIO).....	43
4.13.	ADC.....	44
4.14.	PWM.....	44
4.15.	Network Status Indication.....	45
4.16.	Operating Status Indication.....	45
4.17.	LED Interface.....	46
4.18.	RF Synchronization Signal.....	46
4.19.	Antenna Interface.....	47
4.19.1.	GSM Antenna Interface.....	47
4.19.2.	Bluetooth Antenna Interface.....	48
4.19.3.	FM Antenna Interface.....	49
<b>5.</b>	<b>PCB Layout.....</b>	<b>50</b>
5.1	Pin Assignment.....	50
5.2	Principle of PCB Layout.....	51
5.2.1	Antenna Interface.....	51
5.2.2.	Power Supply.....	51
5.2.3	SIM Card Interface.....	51
5.2.4	Audio Interface.....	51
5.2.5	Others.....	51
5.3	Recommended PCB Layout.....	52
<b>6.</b>	<b>Electrical, Reliability and Radio Characteristics.....</b>	<b>53</b>
6.1	Absolute Maximum Ratings.....	53
6.2	Recommended Operating Conditions.....	53
6.3	Digital Interface Characteristics.....	53
6.4	SIM Card Interface Characteristics.....	54
6.5	SIM_VDD Characteristics.....	54
6.6	VDD_EXT Characteristics.....	54
6.7	VRTC Characteristics.....	54
6.8	Current Consumption (VBAT=3.8V).....	55
6.9	Electro-Static Discharge.....	58
6.10	Radio Characteristics.....	58
6.10.1.	Module RF Output Power.....	58
6.10.2.	Module RF Receive Sensitivity.....	59

6.10.3.	Module Operating Frequencies.....	59
<b>7.</b>	<b>Manufacturing .....</b>	<b>60</b>
7.1.	Top and Bottom View of SIM800H .....	60
7.2.	Typical Solder Reflow Profile .....	60
7.3.	The Moisture Sensitivity Level.....	61
7.4.	Baking Requirements .....	61
<b>8.</b>	<b>Appendix.....</b>	<b>62</b>
I.	Related Documents .....	62
II.	Terms and Abbreviations .....	63
III.	Safety Caution.....	65

SIMCOM CONFIDENTIAL FILE

## Table Index

TABLE 1: MODULE INFORMATION .....	11
TABLE 2: SIM800H KEY FEATURES .....	11
TABLE 3: CODING SCHEMES AND MAXIMUM NET DATA RATES OVER AIR INTERFACE .....	13
TABLE 4: OVERVIEW OF OPERATING MODES .....	13
TABLE 5: PIN DESCRIPTION .....	16
TABLE 6: RECOMMENDED ZENER DIODE .....	20
TABLE 7: ELECTRONIC CHARACTERISTIC OF THE RESET PIN .....	25
TABLE 8: THE CURRENT CONSUMPTION OF MINIMUM FUNCTIONALITY MODE (BS-PA-MFRMS=9) .....	26
TABLE 9: SERIAL PORT AND USB PIN DEFINITION .....	28
TABLE 10: SERIAL PORT CHARACTERISTICS .....	28
TABLE 11: VBUS OPERATION VOLTAGE .....	31
TABLE 12: RI BEHAVIORS .....	32
TABLE 13: AUDIO INTERFACE DEFINITION .....	33
TABLE 14: PERFORMANCE OF AUDIO AMPLIFIER .....	34
TABLE 15: MICROPHONE INPUT CHARACTERISTICS .....	35
TABLE 16: AUDIO OUTPUT CHARACTERISTICS .....	35
TABLE 17: SIM PIN DEFINITION .....	36
TABLE 18: PIN DESCRIPTION (MOLEX SIM CARD HOLDER) .....	38
TABLE 19: PIN DESCRIPTION (AMPHENOL SIM CARD HOLDER) .....	39
TABLE 20: PCM PIN DEFINITION .....	39
TABLE 21: PCM SPECIFICATION .....	40
TABLE 22: PIN DEFINITION OF THE KEYPAD INTERFACE .....	42
TABLE 23: PIN DEFINITION OF THE I2C .....	43
TABLE 24: PIN DEFINITION OF THE GPIO .....	43
TABLE 25: PIN DEFINITION OF THE ADC .....	44
TABLE 26: ADC SPECIFICATION .....	44
TABLE 27: PIN DEFINITION OF THE PWM .....	44
TABLE 28: BUZZER CHARACTERISTICS .....	45
TABLE 29: PIN DEFINITION OF THE NETLIGHT .....	45
TABLE 30: STATUS OF THE NETLIGHT PIN .....	45
TABLE 31: PIN DEFINITION OF THE STATUS .....	46
TABLE 32: PIN DEFINITION OF THE LED .....	46
TABLE 33: ISINK SPECIFICATION .....	46
TABLE 34: DEFINITION OF THE RF_SYNC PIN .....	46
TABLE 35: RECOMMENDED TRANSIENT VOLTAGE SUPPRESSOR .....	48
TABLE 36: ABSOLUTE MAXIMUM RATINGS .....	53
TABLE 37: RECOMMENDED OPERATING CONDITIONS .....	53
TABLE 38: DIGITAL INTERFACE CHARACTERISTICS .....	53
TABLE 39: SIM CARD INTERFACE CHARACTERISTICS .....	54
TABLE 40: SIM_VDD CHARACTERISTICS .....	54
TABLE 41: VDD_EXT CHARACTERISTICS .....	54
TABLE 42: VRTC CHARACTERISTICS .....	54
TABLE 43: CURRENT CONSUMPTION .....	55
TABLE 44: BLUETOOTH CHARACTERISTICS .....	56
TABLE 45: CURRENT CONSUMPTION OF BLUETOOTH .....	57

TABLE 46: THE ESD CHARACTERISTICS (TEMPERATURE: 25°C, HUMIDITY: 45 %)	58
TABLE 47: GSM850 AND EGSM900 CONDUCTED RF OUTPUT POWER	58
TABLE 48: DCS1800 AND PCS1900 CONDUCTED RF OUTPUT POWER	59
TABLE 49: CONDUCTED RF RECEIVE SENSITIVITY	59
TABLE 50: OPERATING FREQUENCIES	59
TABLE 51: MOISTURE SENSITIVITY LEVEL AND FLOOR LIFE	61
TABLE 52: BAKING REQUIREMENTS	61
TABLE 53: RELATED DOCUMENTS	62
TABLE 54: TERMS AND ABBREVIATIONS	63
TABLE 55: SAFETY CAUTION	65

SIMCOM CONFIDENTIAL FILE

## Figure Index

FIGURE 1: SIM800H FUNCTIONAL DIAGRAM.....	14
FIGURE 2: PIN ASSIGNMENT (TOP VIEW).....	15
FIGURE 3: DIMENSIONS OF SIM800H (UNIT: MM) .....	18
FIGURE 4: RECOMMENDED PCB FOOTPRINT OUTLINE (UNIT: MM) .....	19
FIGURE 5: REFERENCE CIRCUIT OF THE VBAT INPUT.....	20
FIGURE 6: REFERENCE CIRCUIT OF THE LDO POWER SUPPLY .....	20
FIGURE 7: REFERENCE CIRCUIT OF THE DC-DC POWER SUPPLY .....	21
FIGURE 8: VBAT VOLTAGE DROP DURING TRANSMIT BURST.....	21
FIGURE 9: THE MINIMAL VBAT VOLTAGE REQUIREMENT AT VBAT DROP .....	22
FIGURE 10: POWERED ON/OFF MODULE USING TRANSISTOR.....	22
FIGURE 11: POWERED ON/OFF MODULE USING BUTTON .....	22
FIGURE 12: TIMING OF POWER ON MODULE.....	23
FIGURE 13: TIMING OF POWER DOWN SIM800H BY PWRKEY .....	23
FIGURE 14:TIMING OF RESTART SIM800H .....	24
FIGURE 15: RESET CIRCUIT.....	25
FIGURE 16: RESET TIMING SEQUENCE.....	25
FIGURE 17: RTC SUPPLY FROM CAPACITOR.....	27
FIGURE 18: RTC SUPPLY FROM NON-CHARGEABLE BATTERY.....	27
FIGURE 19: RTC SUPPLY FROM RECHARGEABLE BATTERY .....	27
FIGURE 20: CONNECTION OF THE SERIAL INTERFACES.....	29
FIGURE 21: RESISTOR MATCHING CIRCUIT .....	30
FIGURE 22: DIODE ISOLATION CIRCUIT.....	30
FIGURE 23: TX LEVEL MATCHING CIRCUIT .....	30
FIGURE 24: RX LEVEL MATCHING CIRCUIT .....	31
FIGURE 25: USB REFERENCE CIRCUIT .....	31
FIGURE 26: CONNECTION FOR SOFTWARE UPGRADING AND DEBUGGING .....	32
FIGURE 27: RI BEHAVIOUR OF VOICE CALLING AS A RECEIVER.....	33
FIGURE 28: RI BEHAVIOUR OF URC OR RECEIVE SMS .....	33
FIGURE 29: RI BEHAVIOUR AS A CALLER .....	33
FIGURE 30: SPEAKER REFERENCE CIRCUIT .....	34
FIGURE 31: SPEAKER WITH AMPLIFIER REFERENCE CIRCUIT .....	35
FIGURE 32: REFERENCE CIRCUIT OF THE 8-PIN SIM CARD HOLDER.....	36
FIGURE 33: REFERENCE CIRCUIT OF THE 6-PIN SIM CARD HOLDER.....	37
FIGURE 34: MOLEX 91228 SIM CARD HOLDER.....	38
FIGURE 35: AMPHENOL C707 10M006 512 SIM CARD HOLDER.....	39
FIGURE 36: PCM REFERENCE CIRCUIT .....	40
FIGURE 37: 25 KEYS REFERENCE CIRCUIT.....	41
FIGURE 38: 50 KEYS REFERENCE CIRCUIT .....	41
FIGURE 39: KEYPAD REFERENCE CIRCUIT .....	42
FIGURE 40: KEYPAD DETECTED .....	42
FIGURE 41: GPIO TIMING SEQUENCES .....	43
FIGURE 42: REFERENCE CIRCUIT OF PWM DRIVER BUZZER .....	44
FIGURE 43: REFERENCE CIRCUIT OF NETLIGHT.....	45
FIGURE 44: LED DRIVER REFERENCE CIRCUIT.....	46
FIGURE 45: RF_SYNC SIGNAL DURING TRANSMIT BURST .....	47
FIGURE 46: GSM ANTENNA MATCHING CIRCUIT.....	47



FIGURE 47: GSM SIMPLE ANTENNA MATCHING CIRCUIT .....	48
FIGURE 48: BLUETOOTH ANTENNA MATCHING CIRCUIT .....	48
FIGURE 49: FM ANTENNA MATCHING CIRCUIT .....	49
FIGURE 50: GND PIN OF THE EARPHONE USE TO BE THE FM ANTENNA INTERFACE.....	49
FIGURE 51: PIN ASSIGNMENT .....	50
FIGURE 52: RECOMMENDED PCB LAYOUT .....	52
FIGURE 53: TOP AND BOTTOM VIEW OF SIM800H .....	60
FIGURE 54: TYPICAL SOLDER REFLOW PROFILE OF LEAD-FREE PROCESSES.....	60

SIMCOM CONFIDENTIAL FILE

## Version History

Date	Version	Description of change	Author
2013-08-01	1.00	Origin	Jialin.song; Ya.li
2013-08-20	1.01	Update figure 15, figure 23, figure 32, figure 54 Update Bluetooth matching (R201 is 1.2nH, C202 is 1.5pF) Update 7.3 and 7.4 paragraph Change 300us to 105ms in the table 6 Update table 1,table 7	Jialin.song; Ya.li
2014-07-03	2.01	Update Figure 12,Figure 13,Figure 20 Update Table 7 Update Serial port baud rates Add note of the SIM design Add notes of the KEYPAD design Add “4.2.2.5 Restart SIM800H/L by PWRKEY Pin” Add “4.3.4 and 4.3.5” sleep mode 2(AT+CSCLK=2) Add “4.18.1 RF_SYNC Multiplexing Function ” Modify max value of the VBUS in table 42 Add table 50 and table 51	Jialin.song
2015-07-27	V2.02	Modify KBC0 described in table 5 Modify Figure 12 Modify Table 44 “Bluetooth specification Version3.0” Modify Table 38 “Parameter”	Jialin.song
2016-10-10	V2.03	Update Figure 46, 47, add TVS for ESD protection Delete the multiplexing function Add note of the over-voltage or under-voltage power down Add note of the ADC function Update Figure 4 Delete 4.2.2.4 Over-Temperature or Under-Temperature Power Down	Ajuan.zhu

## 1. Introduction

This document describes SIM800H hardware interface in great detail. The document can help customer to quickly understand SIM800H interface specifications, electrical and mechanical details. With the help of this document and other SIM800H application notes, customer guide, customers can use SIM800H to design various applications quickly.

## 2. SIM800H Overview

SIM800H is a quad-band GSM/GPRS module, that works on frequencies GSM850MHz, EGSM900MHz, DCS1800MHz and PCS1900MHz.

With a tiny configuration of 17.8\*15.8\*2.4mm, SIM800H can meet almost all the space requirements in customer applications, such as smart phone, PDA and other mobile devices.

SIM800H is a LGA package with 88 pads, and provides all hardware interfaces between the module and customers' boards.

- Support 5\*5\*2 keypads
- One full modem serial port, customer can configure two serial ports
- One USB, the USB interfaces can debug, download software
- Audio channel which includes two microphone input; a receiver output and a speaker output
- Programmable general purpose input and output.
- A SIM card interface
- Support Bluetooth
- Support FM
- Support one PWM

SIM800H is designed with power saving technique so that the current consumption is as low as 1.04mA in sleep mode.

### 2.1. SIM800H

**Table 1: Module information**

	<b>SIM800H</b>
GSM	850,900,1800 and 1900MHz
BT	Support
FLASH	32Mbit
RAM	32Mbit

### 2.2. SIM800H Key Features

**Table 2: SIM800H key features**

<b>Feature</b>	<b>Implementation</b>
Power supply	3.4V ~4.4V

Power saving	Typical power consumption in sleep mode is 1.04mA (BS_PA_MFRMS=9 )
Frequency bands	<ul style="list-style-type: none"> <li>● Quad-band: GSM 850, EGSM 900, DCS 1800, PCS 1900. SIM800H can search the 4 frequency bands automatically. The frequency bands can also be set by AT command “AT+CBAND”. For details, please refer to <i>document [1]</i>.</li> <li>● Compliant to GSM Phase 2/2+</li> </ul>
Transmitting power	<ul style="list-style-type: none"> <li>● Class 4 (2W) at GSM 850 and EGSM 900</li> <li>● Class 1 (1W) at DCS 1800 and PCS 1900</li> </ul>
GPRS connectivity	<ul style="list-style-type: none"> <li>● GPRS multi-slot class 12 ( default )</li> <li>● GPRS multi-slot class 1~12 (option)</li> </ul>
Temperature range	<ul style="list-style-type: none"> <li>● Normal operation: -40°C ~ +85°C</li> <li>● Storage temperature -45°C ~ +90°C</li> </ul>
Data GPRS	<ul style="list-style-type: none"> <li>● GPRS data downlink transfer: max. 85.6 kbps</li> <li>● GPRS data uplink transfer: max. 85.6 kbps</li> <li>● Coding scheme: CS-1, CS-2, CS-3 and CS-4</li> <li>● PAP protocol for PPP connect</li> <li>● Integrate the TCP/IP protocol.</li> <li>● Support Packet Broadcast Control Channel (PBCCH)</li> </ul>
USSD	<ul style="list-style-type: none"> <li>● Unstructured Supplementary Services Data (USSD) support</li> </ul>
SMS	<ul style="list-style-type: none"> <li>● MT, MO, CB, Text and PDU mode</li> <li>● SMS storage: SIM card</li> </ul>
SIM interface	Support SIM card: 1.8V, 3V
External antenna	Antenna pad
Audio features	<p>Speech codec modes:</p> <ul style="list-style-type: none"> <li>● Half Rate (ETS 06.20)</li> <li>● Full Rate (ETS 06.10)</li> <li>● Enhanced Full Rate (ETS 06.50 / 06.60 / 06.80)</li> <li>● Adaptive multi rate (AMR)</li> <li>● Echo Cancellation</li> <li>● Noise Suppression</li> </ul>
Serial port and debug port	<p><b>Serial port:</b></p> <ul style="list-style-type: none"> <li>● Default one Full modem serial port</li> <li>● 1200bps to 460800bps.</li> <li>● Can be used for AT commands or data stream.</li> <li>● Support RTS/CTS hardware handshake and software ON/OFF flow control.</li> <li>● Multiplex ability according to GSM 07.10 Multiplexer Protocol.</li> <li>● Autobauding supports baud rate from 1200 bps to 115200bps.</li> <li>● upgrading firmware</li> </ul> <p><b>Debug port:</b></p> <ul style="list-style-type: none"> <li>● USB_DN and USB_DP</li> <li>● Can be used for debugging and upgrading firmware.</li> </ul>
Phonebook management	Support phonebook types: SM, FD, LD, RC, ON, MC.
SIM application toolkit	GSM 11.14 Release 99
Real time clock	Support RTC
Timing functions	Use AT command set

Physical characteristics	Size: 17.8*15.8*2.4mm Weight:1.35g
Firmware upgrade	Main serial port or USB port.(recommend to use USB port)

**Table 3: Coding schemes and maximum net data rates over air interface**

Coding scheme	1 timeslot	2 timeslot	4 timeslot
CS-1	9.05kbps	18.1kbps	36.2kbps
CS-2	13.4kbps	26.8kbps	53.6kbps
CS-3	15.6kbps	31.2kbps	62.4kbps
CS-4	21.4kbps	42.8kbps	85.6kbps

### 2.3. Operating Mode

The table below summarizes the various operating modes of SIM800H.

**Table 4: Overview of operating modes**

Mode	Function
Normal operation	GSM/GPRS SLEEP Module will automatically go into sleep mode if the conditions of sleep mode are enabling and there is no on air and no hardware interrupt (such as GPIO interrupt or data on serial port). In this case, the current consumption of module will reduce to the minimal level. In sleep mode, the module can still receive paging message and SMS.
	GSM IDLE Software is active. Module is registered to the GSM network, and the module is ready to communicate.
	GSM TALK Connection between two subscribers is in progress. In this case, the power consumption depends on network settings such as DTX off/on, FR/EFR/HR, hopping sequences, antenna.
	GPRS STANDBY Module is ready for GPRS data transfer, but no data is currently sent or received. In this case, power consumption depends on network settings and GPRS configuration.
	GPRS DATA There is GPRS data transfer (PPP or TCP or UDP) in progress. In this case, power consumption is related with network settings (e.g. power control level); uplink/downlink data rates and GPRS configuration (e.g. used multi-slot settings).
Power down	Normal power down by sending AT command “AT+CPOWD=1” or using the PWRKEY. The power management unit shuts down the power supply for the baseband part of the module, and only the power supply for the RTC is remained. Software is not active. The serial port is not accessible. Power supply (connected to VBAT) remains applied.
Minimum functionality mode	AT command “AT+CFUN” can be used to set the module to a minimum functionality mode without removing the power supply. In this mode, the RF part of the module will not work or the SIM card will not be accessible, or both RF part and SIM card will be closed, and the serial port is still accessible. The power consumption in this mode is lower than normal mode.

## 2.4. Functional Diagram

The following figure shows a functional diagram of SIM800H:

- GSM baseband
- GSM RF
- Antenna interface
- Other interface

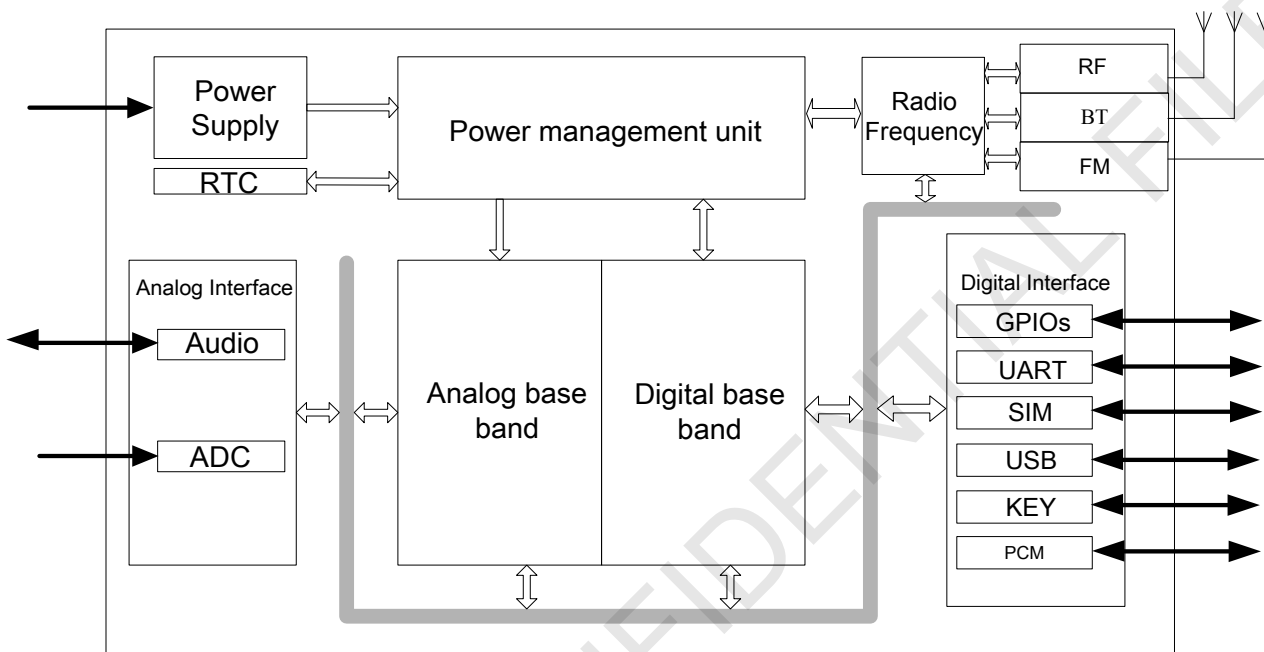


Figure 1: SIM800H functional diagram

### 3. Package Information

#### 3.1. Pin Out Diagram

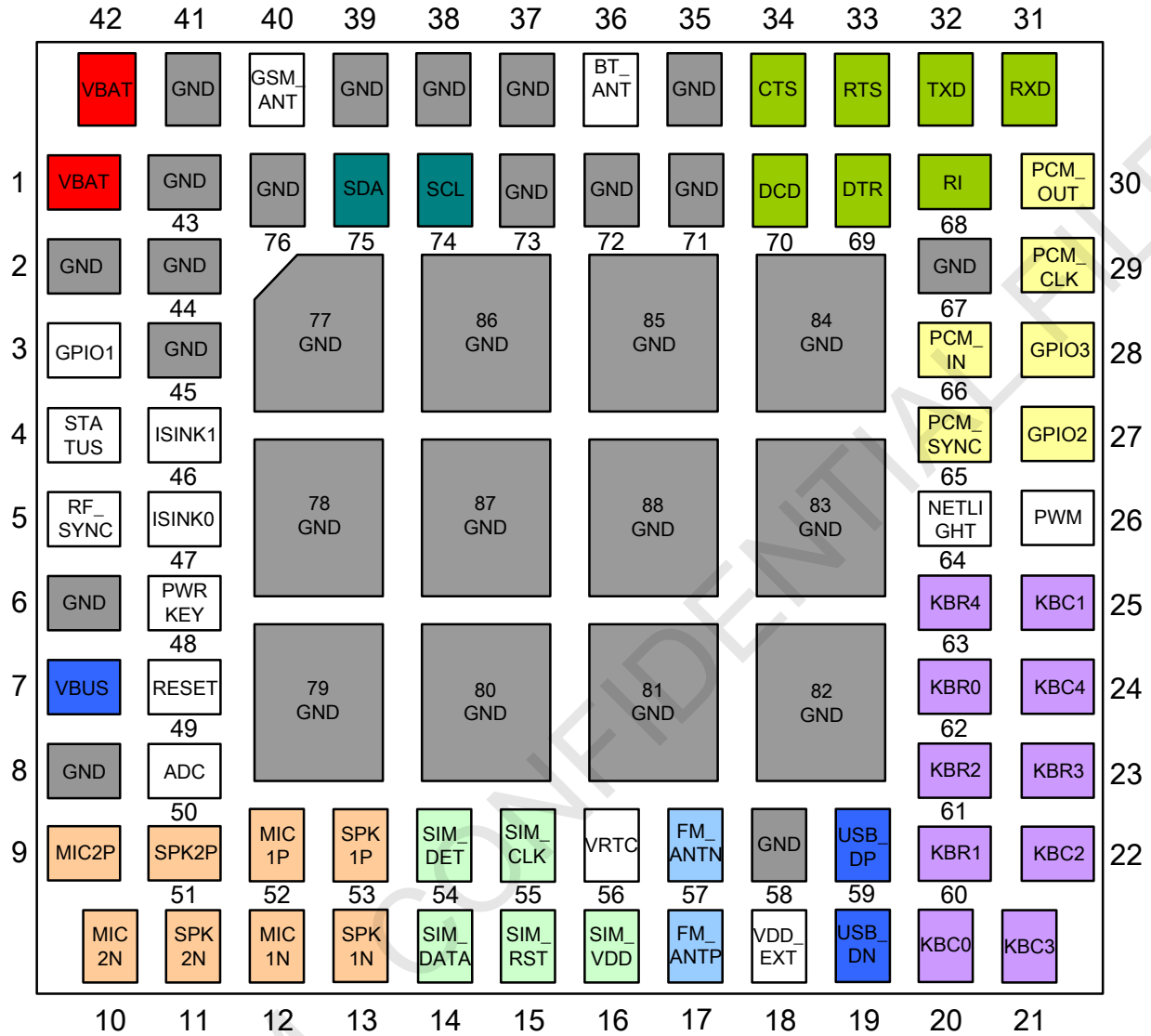


Figure 2: Pin assignment (Top view)

### 3.2. Pin Description

**Table 5: Pin description**

Pin name	Pin number	I/O	Description	Comment
<b>Power supply</b>				
VBAT	1,42	I	Power supply	
VRTC	56	I/O	Power supply for RTC	It is recommended to connect with a battery or a capacitor (e.g. 4.7uF).
VDD_EXT	18	O	2.8V power output	If these pins are unused, keep open.
GND	2,6,8,35,37,38,39,41,43,44,45,58,67,71,72,73,76,77,78,79,80,81,82,83,84,85,86,87,88		Ground	GND for VBAT recommend to use 2,43,44,45pin
<b>Power on/down</b>				
PWRKEY	48	I	PWRKEY should be pulled low at least 1 second and then released to power on/down the module.	Internally pulled up to VBAT.
<b>Audio interfaces</b>				
MIC1P	52	I	Differential audio input	If these pins are unused, keep open.
MIC1N	12			
SPK1P	53	O	Differential audio output	
SPK1N	13			
MIC2P	9	I	Differential audio input	
MIC2N	10			
SPK2P	51	O	Differential audio output	
SPK2N	11			
<b>PCM interface</b>				
PCM_CLK	29	O	PCM interface for digital audio	If these pins are unused, keep open.
PCM_OUT	30	O		
PCM_SYNC	65	O		
PCM_IN	66	I		
<b>Keypads interface</b>				
KBC4	24	I	Support up to 50 buttons (5*5*2)	If these pins are unused, keep open. (Please make sure pin20 at high level when power on)
KBC3	21	I		
KBC2	22	I		
KBC1	25	I		
KBC0	20	I		
KBR4	63	O		
KBR3	23	O		



KBR2	61	O		
KBR1	60	O		
KBR0	62	O		
<b>GPIO</b>				
GPIO1	3	I/O	Programmable general purpose input and output	
GPIO2	27	I/O		
GPIO3	28	I/O		
NETLIGHT	64	O	Network status	
STATUS	4	O	Power on status	
<b>Serial port</b>				
DTR	69	I	Data terminal ready	If these pins are unused, keep open.
RI	68	O	Ring indicator	
DCD	70	O	Data carrier detect	
CTS	34	O	Request to send	
RTS	33	I	Clear to send	
TXD	32	O	Transmit data	
RXD	31	I	Receive data	
<b>Debug interface</b>				
VBUS	7	I	Debug and download	If these pins are unused, keep open.
USB_DP	59	I/O		
USB_DN	19	I/O		
<b>ADC</b>				
ADC	50	I	10bit general analog to digital converter	If these pins are unused, keep open.
<b>PWM</b>				
PWM	26	O	Pulse-width modulation	If these pins are unused, keep open.
<b>I2C</b>				
SDA	75	I/O	Open drain output	If these pins are unused, keep open.
SCL	74	O	Open drain output	
<b>SIM card interface</b>				
SIM_VDD	16	O	Voltage supply for SIM card. Support 1.8V or 3V SIM card	All signals of SIM interface should be protected against ESD with a TVS diode array.
SIM_DATA	14	I/O	SIM data input/output	
SIM_CLK	55	O	SIM clock	
SIM_RST	15	O	SIM reset	
SIM_DET	54	I	SIM card detection	If these pins are unused, keep open.
<b>Antenna interface</b>				
GSM_ANT	40	I/O	Connect GSM antenna	
BT_ANT	36	I/O	Connect Bluetooth antenna	Only SIM800H
FM_ANTP	17	I	Differential antenna for FM	

FM_ANTN	57	I	Differential antenna for FM	
<b>Synchronizing signal of RF</b>				
RF_SYNC	5	O	Synchronizing signal of RF	
<b>Other</b>				
RESET	49	I	Reset input(Active low)	
ISINK1	46	I	Drive keypad backlight	
ISINK0	47	I	Drive LCD backlight	

### 3.3. Package Dimensions

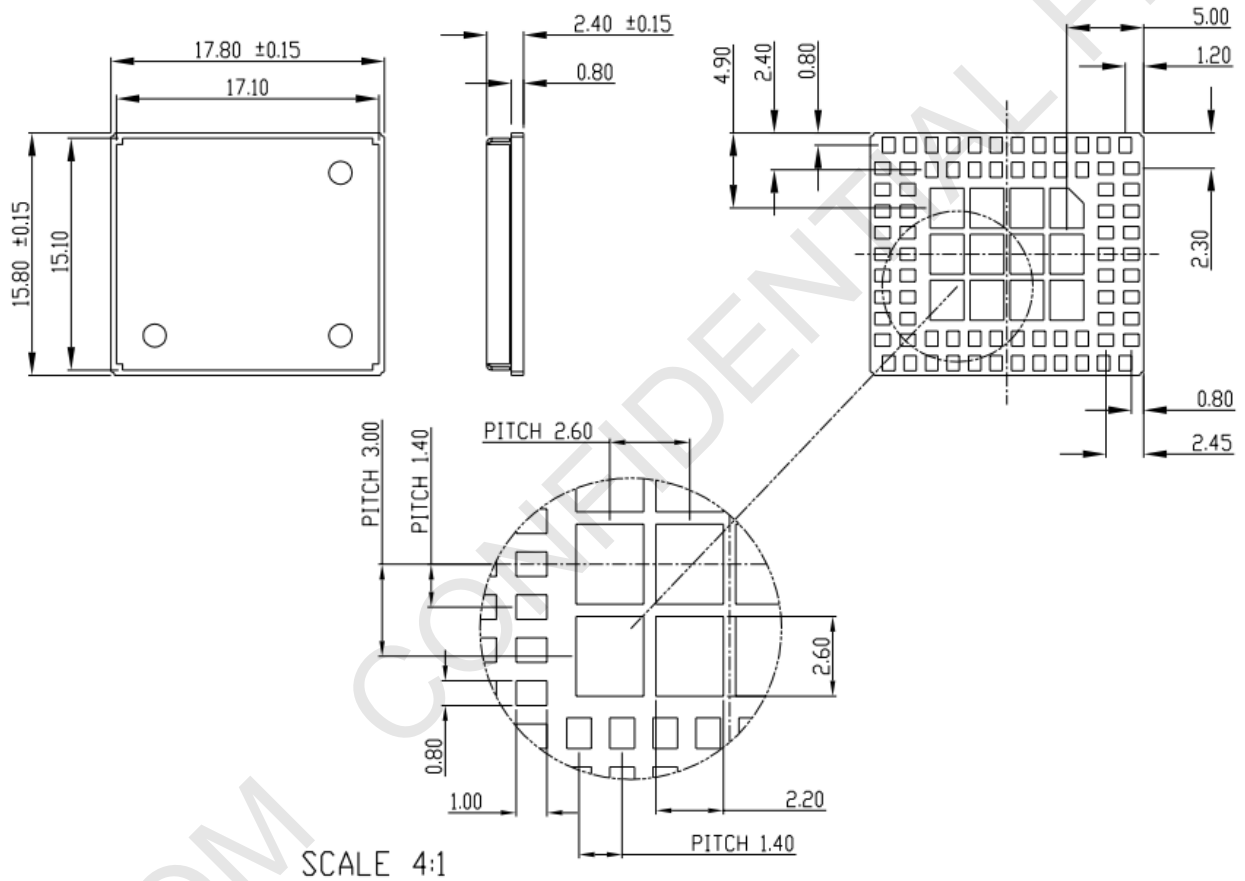


Figure 3: Dimensions of SIM800H (Unit: mm)

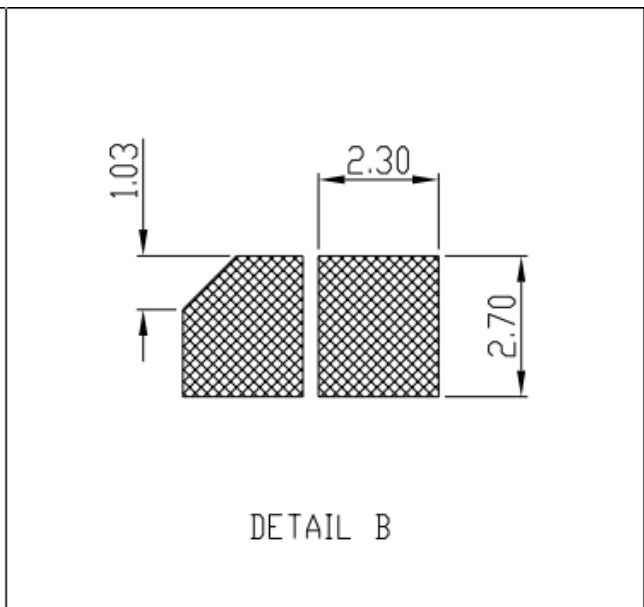
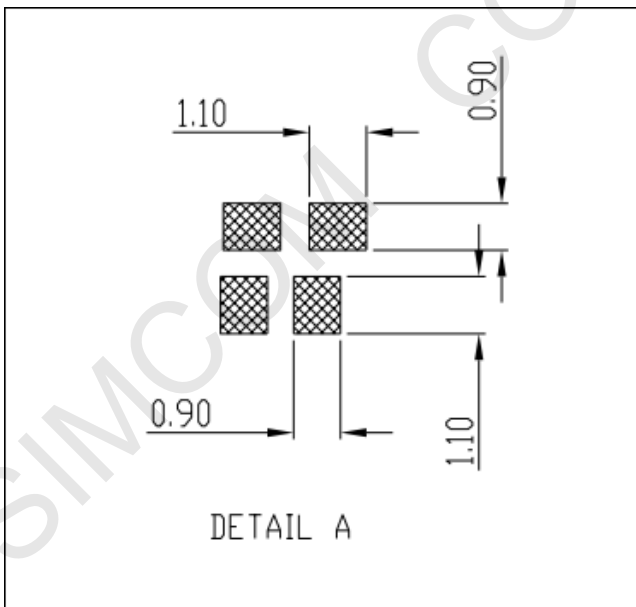
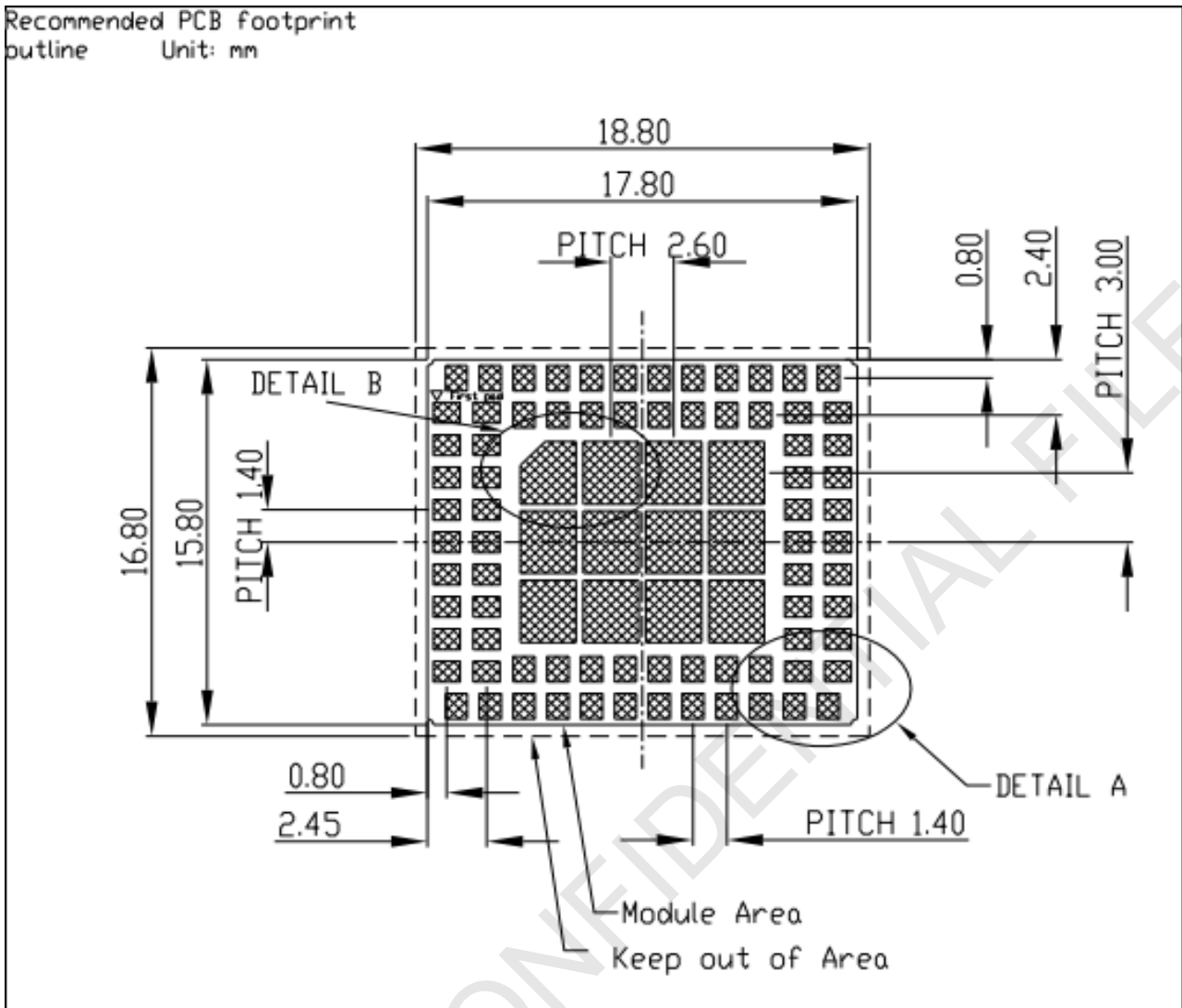


Figure 4: Recommended PCB footprint outline (Unit: mm)

## 4. Application Interface

### 4.1. Power Supply

The power supply range of SIM800H is from 3.4V to 4.4V. Recommended voltage is 4.0V. The transmitting burst will cause voltage drop and the power supply must be able to provide sufficient current up to 2A. For the VBAT input, a bypass capacitor (low ESR) such as a 100  $\mu$ F is strongly recommended.

Increase the 33pF and 10pF capacitors can effectively eliminate the high frequency interference. A 5.1V/500mW Zener diode is strongly recommended, the diode can prevent chip from damaging by the voltage surge. These capacitors and Zener diode should be placed as close as possible to SIM800H VBAT pins.

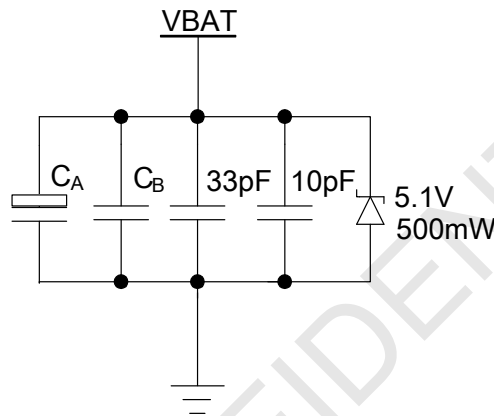


Figure 5: Reference circuit of the VBAT input

Table 6: Recommended zener diode

	Vendor	Part number	Power(watts)	Packages
1	On semi	MMSZ5231BT1G	500mW	SOD123
2	Prisemi	PZ3D4V2H	500mW	SOD323
3	Vishay	MMSZ4689-V	500mW	SOD123
4	Crownpo	CDZ55C5V1SM	500mW	0805

The following figure is the reference design of +5V input power supply. The designed output for the power supply is 4.1V, thus a linear regulator can be used.

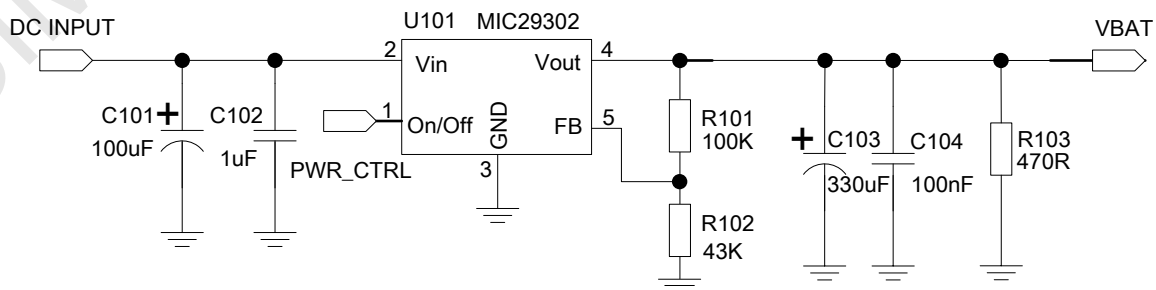
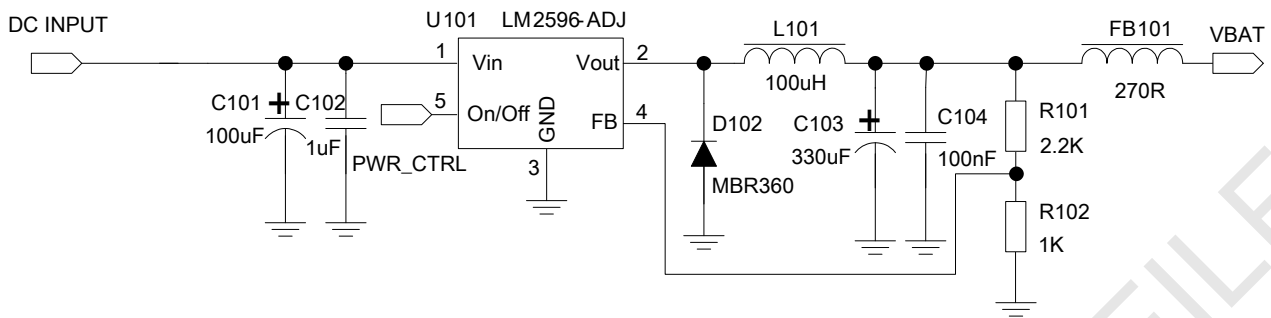


Figure 6: Reference circuit of the LDO power supply

If there is a high drop-out between the input and the desired output (VBAT), a DC-DC power supply will be preferable because of its better efficiency especially with the 2A peak current in burst mode of the module. The following figure is the reference circuit.



**Figure 7: Reference circuit of the DC-DC power supply**

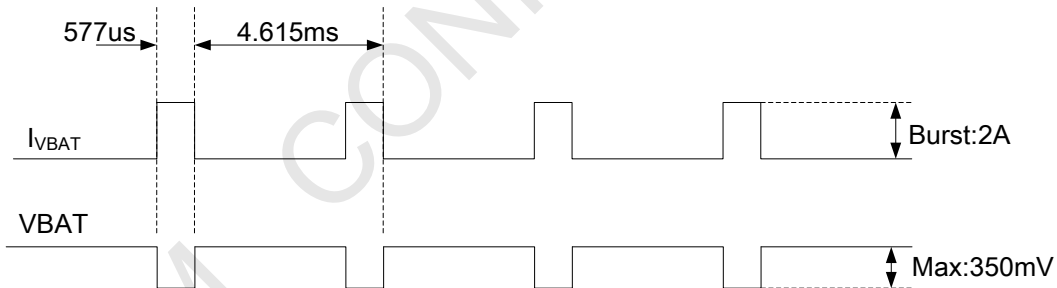
The single 3.7V Li-ion cell battery can be connected to SIM800H VBAT pins directly. But the Ni-Cd or Ni-MH battery must be used carefully, since their maximum voltage can rise over the absolute maximum voltage of the module and damage it.

When battery is used, the total impedance between battery and VBAT pins should be less than 150mΩ. The following figure shows the VBAT voltage drop at the maximum power transmit phase, and the test condition is as following:

VBAT=4.0V,

A VBAT bypass capacitor  $C_A=100\mu\text{F}$  tantalum capacitor (ESR=0.7Ω),

Another VBAT bypass capacitor  $C_B=1\mu\text{F}$ .

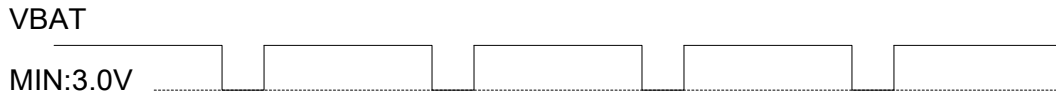


**Figure 8: VBAT voltage drop during transmit burst**

#### 4.1.1. Power Supply Pin

Pin 1 and Pin 42 are VBAT input, Pins 2,43,44,45 are GND of power supply, VRTC pin is power supply of the RTC circuit in the module. VDD\_EXT output 2.8V when module is in normal operation mode.

When designing the power supply in customer’s application, pay special attention to power losses. Ensure that the input voltage never drops below 3.0V even when current consumption rises to 2A in the transmit burst. If the power voltage drops below 3.0V, the module may be shut down automatically. The PCB traces from the VBAT pins to the power supply must be wide enough (at least 60mil) to decrease voltage drops in the transmit burst. The power IC and the bypass capacitor should be placed to the module as close as possible.



**Figure 9: The minimal VBAT voltage requirement at VBAT drop**

*Note: Hardware power down voltage is 3.0V.*

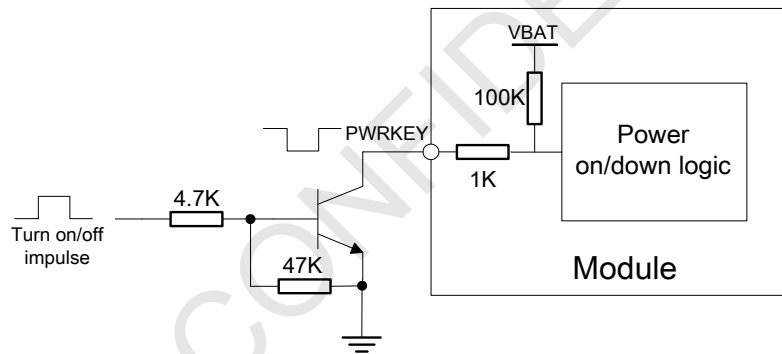
#### 4.1.2. Monitoring Power Supply

AT command “AT+CBC” can be used to monitor the VBAT voltage. For detail, please refer to *document [1]*.

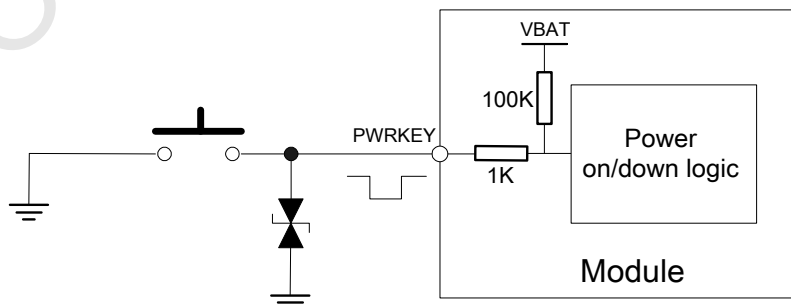
### 4.2. Power on/off Scenarios

#### 4.2.1. Power on SIM800H

Customer can power on SIM800H by pulling down the PWRKEY pin for at least 1 second and release. This pin is already pulled up to VBAT in the module internal, so external pull up is not necessary. Reference circuit is shown as below.



**Figure 10: Powered on/off module using transistor**



**Figure 11: Powered on/off module using button**

The power on timing is illustrated as in the following figure.

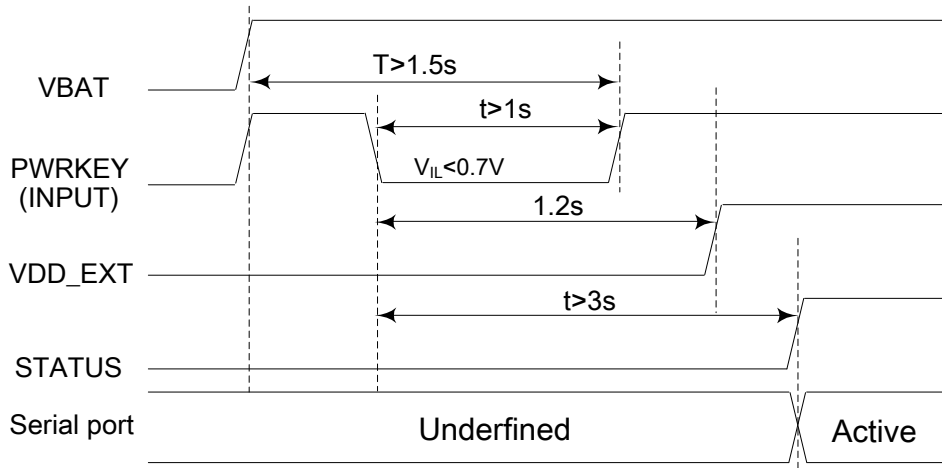


Figure 12: Timing of power on module

When power on procedure is completed, SIM800H will send following URC to indicate that the module is ready to operate at fixed baud rate.

#### **RDY**

This URC does not appear when autobauding function is active.

*Note: Customer can use AT command "AT+IPR=x" to set a fixed baud rate and save the configuration to non-volatile flash memory. After the configuration is saved as fixed baud rate, the Code "RDY" should be received from the serial port every time when SIM800H is powered on. For details, please refer to the chapter "AT+IPR" in document [1].*

### 4.2.2. Power down SIM800H

SIM800H will be powered down in the following situations:

- Normal power down procedure: power down SIM800H by the PWRKEY pin.
- Normal power down procedure: power down SIM800H by AT command "AT+CPOWD=1".
- Abnormal power down: over-voltage or under-voltage automatic power down.

#### 4.2.2.1. Power down SIM800H by the PWRKEY Pin

Customer can power down SIM800H by pulling down the PWRKEY pin for at least 1.5 second and release. Please refer to the power on circuit. The power down timing is illustrated in the following figure.

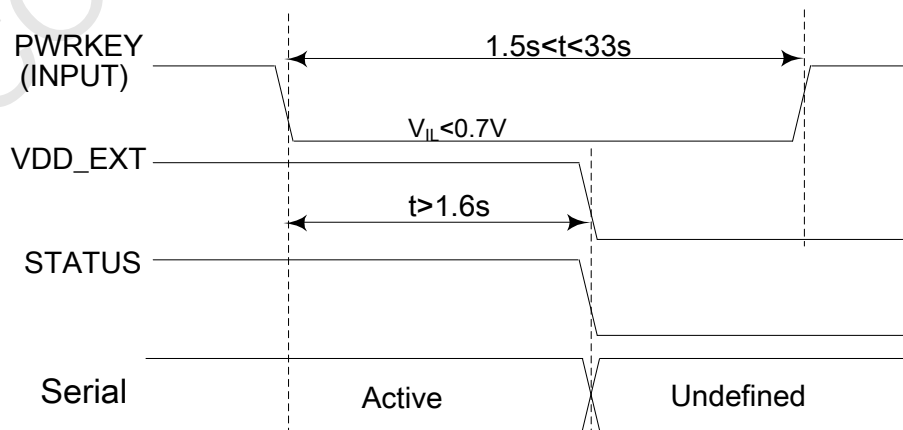


Figure 13: Timing of power down SIM800H by PWRKEY

This procedure makes the module log off from the network and allows the software to enter into a secure state to

save data before completely shut down. Before the power down procedure, the module will send URC:

***NORMAL POWER DOWN***

At this moment, AT commands can not be executed any more, and only the RTC is still active. Power down mode can also be indicated by STATUS or VDD\_EXT, which is at low level at this time.

**4.2.2.2. Power down SIM800H by AT Command**

SIM800H can be powered down by AT command “AT+CPOWD=1”. This procedure makes the module log off from the network and allows the software to enter into a secure state to save data before completely shut down. Before the completion of the power down procedure, the module will send URC:

***NORMAL POWER DOWN***

At this moment, AT commands can not be executed any more, and only the RTC is still active. Power down mode can also be indicated by STATUS or VDD\_EXT, which is at low level at this time.

*Note: For detail about AT command “AT+CPOWD”, please refer to document [1].*

**4.2.2.3. Over-Voltage or Under-Voltage Power Down**

The module software monitors the VBAT voltage constantly.

If the voltage  $\leq 3.5V$ , the following URC will be reported:

***UNDER-VOLTAGE WARNNING***

If the voltage  $\geq 4.3V$ , the following URC will be reported:

***OVER-VOLTAGE WARNNING***

If the voltage  $< 3.4V$ , the following URC will be reported, and the module will be automatically powered down.

***UNDER-VOLTAGE POWER DOWN***

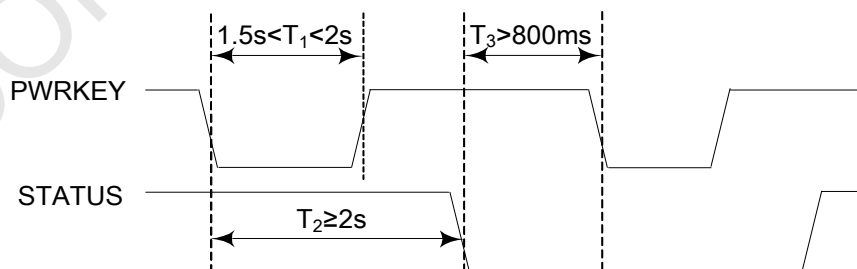
If the voltage  $> 4.4V$ , the following URC will be reported, and the module will be automatically powered down.

***OVER-VOLTAGE POWER DOWN***

At this moment, AT commands can not be executed any more, and only the RTC is still active. Power down mode can also be indicated by STATUS or VDD\_EXT, which is at low level at this time.

**4.2.2.4. Restart SIM800H by PWRKEY Pin:**

When the module works normally, if the customer wants to restart the module, the time after STATUS pin changed to low should be at least 800ms. The module needs enough time to power down completely.



**Figure 14: Timing of restart SIM800H**

**4.2.3. Reset Function**

SIM800H also has a RESET pin (pin 49) used to reset the module. This function is used as an emergency reset only when AT command “AT+CPOWD=1” and the PWRKEY pin has no effect. Customer can pull the RESET



pin to ground, then the module will reset.

This pin is already isolated in the module, so the external isolation is not necessary. Following figure is internal circuit of the RESET pin.

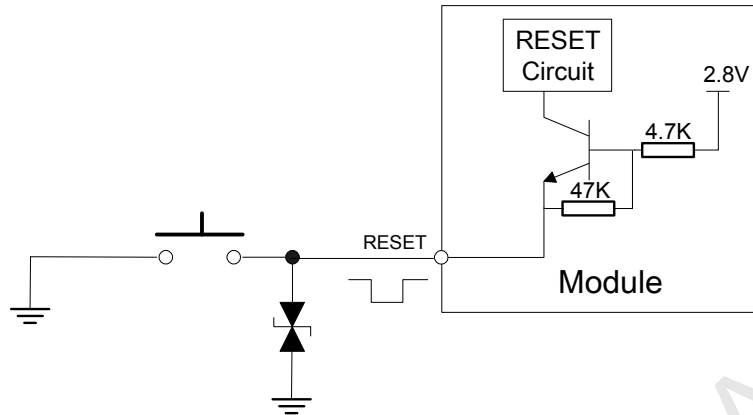


Figure 15: Reset circuit

The typical value of RESET pin at High level is 2.8V, so for the 3V or 3.3V, customer could use MCU’s GPIO to driver this pin directly, cascading some resistors could enhance the ESD performance but the value should not be too big; otherwise the level of RESET could be lower than threshold value; RESET hardware parameters can refer to the table below:

Table 7: Electronic characteristic of the RESET pin

Pin name	Symbol	Min	Typ	Max	Unit
RESET	$V_{IH}$	2.4	2.8	2.9	V
	$V_{IL}$	-	-	0.6	V
	Low power time	105		-	ms

The reset scenarios are illustrated in the following figures.

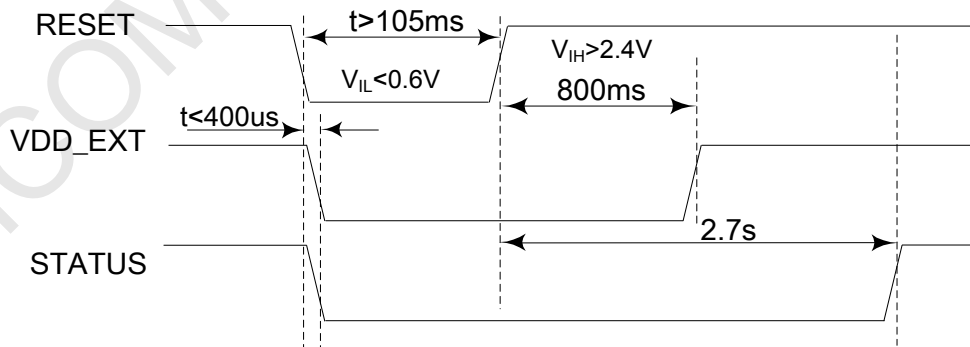


Figure 16: Reset timing sequence

### 4.3. Power Saving Mode

SIM800H has two power saving modes: Minimum functionality mode and sleep mode. AT command “AT+CSCLK=1” can be used to set SIM800H into sleep mode. AT command “AT+CFUN=<fun>” can be used to

set SIM800H into minimum functionality. When SIM800H is in sleep mode and minimum functionality mode, the current of module is lowest.

#### 4.3.1. Minimum Functionality Mode

There are three functionality modes, which could be set by AT command “AT+CFUN=<fun>“. The command provides the choice of the functionality levels <fun>=0,1,4.

- AT+CFUN=0: Minimum functionality.
- AT+CFUN=1: Full functionality (default).
- AT+CFUN=4: Flight mode (disable RF function).

**Table 8: The current consumption of Minimum Functionality Mode (BS-PA-MFRMS=9)**

<fun>	Current consumption(mA) (sleep mode)
0	0.83
1	1.04
4	0.92

Minimum functionality mode minimizes the current consumption to the lowest level. If SIM800H is set to minimum functionality by “AT+CFUN=0”, the RF function and SIM card function will be disabled. In this case, the serial port is still accessible, but all AT commands correlative to RF function and SIM card function will not be accessible.

For detailed information about AT command “AT+CFUN=<fun>“, please refer to *document [1]*.

#### 4.3.2. Sleep Mode 1 (AT+CSCLK=1)

Customer can control SIM800H module to enter or exit the sleep mode (AT+CSCLK=1) by DTR signal. When DTR is in high level and without interrupt (on air and hardware such as GPIO interrupt or data in serial port), SIM800H will enter sleep mode automatically. In this mode, SIM800H can still receive paging or SMS from network but the serial port is not accessible.

#### 4.3.3. Wake Up SIM800H from Sleep Mode 1

When SIM800H is in sleep mode 1(AT+CSCLK=1), the following methods can wake up the module:

- Pull down DTR pin.  
The serial port will be active after DTR pin is pulled to low level for about 50ms.
- Receive a voice or data call from network.
- Receive a SMS from network.
- Receive external interrupt.

*Note: After module has received incoming call or new SMS, serial port can report URC, but the serial port can not input AT command. Only after the DTR pin is pulled to low level for 50ms, the serial port can input AT command.*

#### 4.3.4. Sleep Mode 2 (AT+CSCLK=2)

In this mode, SIM800H will continuously monitor the serial port data signal. When there is no data transfer over 5 seconds on the RXD signal and there is no on air and hardware interrupts (such as GPIO interrupt), SIM800H will enter sleep mode 2 automatically. In this mode, SIM800H/L can still receive paging or SMS from network .

### 4.3.5. Wake Up SIM800H from Sleep Mode 2

When SIM800H is in sleep mode 2 (AT+CSCLK=2), the following methods can wake up the module:

- Send data to SIM800H via main serial port (the first character will lose).
- Receive a voice or data call from network.
- Receive a SMS from network.

*Note: Autobauding is default. It cannot enter sleep mode in the absence of synchronous serial port baud rate after module power on.*

### 4.4. RTC Backup

Current input for RTC when the VBAT is not supplied for the system. Current output for backup battery when the VBAT power supply is in present and the backup battery is in low voltage state. The RTC power supply of module can be provided by an external capacitor or a battery (non-chargeable or rechargeable) through the VRTC. The following figures show various reference circuits for RTC back up.

- External capacitor backup

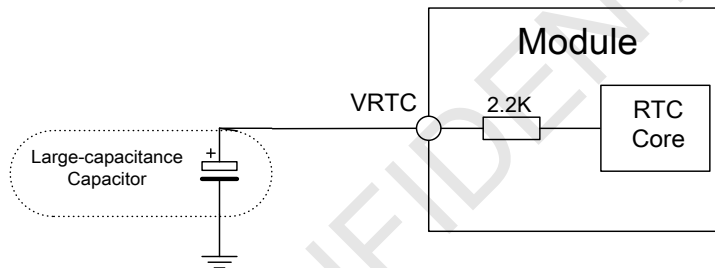


Figure 17: RTC supply from capacitor

- Non-chargeable battery backup

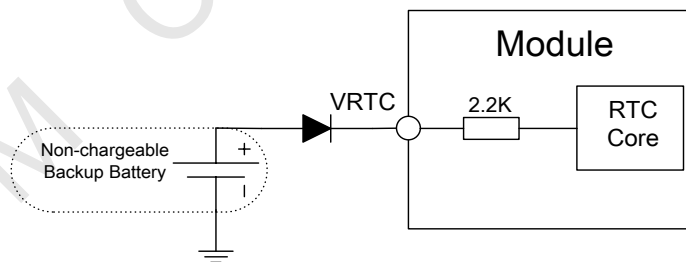


Figure 18: RTC supply from non-chargeable battery

- Rechargeable battery backup

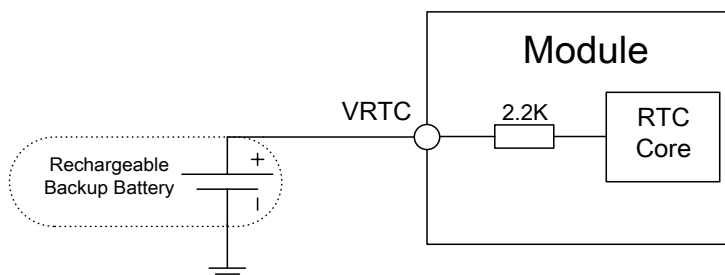


Figure 19: RTC supply from rechargeable battery

*Note: The clock error becomes larger when VBAT is turned off and RTC circuit was supplied from the backup battery or the external capacitor.*

## 4.5. Serial Port and USB Interface

SIM800H default provides one unbalanced asynchronous serial ports. The module is designed as a DCE (Data Communication Equipment). The following figure shows the connection between module and client (DTE).

**Table 9: Serial port and USB pin definition**

	Pin name	Pin number	Function
Serial port	DTR	69	Data terminal ready
	RI	68	Ring indicator
	DCD	70	Data carrier detect
	CTS	34	Request to send
	RTS	33	Clear to send
	TXD	32	Transmit data
	RXD	31	Receive data
Debug port	VBUS	7	USB power supply
	USB_DP	59	USB data line positive
	USB_DN	19	USB data line negative

*Note: Hardware flow control is disable by default. AT command "AT+IFC=2,2" can enable hardware flow control. AT command "AT+IFC=0,0" can disable hardware flow control. For more details please refer to document [1].*

**Table 10: Serial port characteristics**

Symbol	Min	Typ	Max	Unit
V <sub>IL</sub>	-0.3	-	0.7	V
V <sub>IH</sub>	2.1	-	3.1	V
V <sub>OL</sub>	-	-	0.4	V
V <sub>OH</sub>	2.4	2.8	-	V

SIM800H module can support dual serial port function, that need execute AT command "AT+CMNRP=1" first. Dual serial port including one full modem serial port and one three-wire serial port, pin definition is different with standard definition of the Figure 2: Pin assignment (Top view) and Table 5: Pin description. For more details please refer to **Document [2]**.

*Note: Only B05 and later version support dual serial port function.*

### 4.5.1 Function of Serial Port

Serial port:

- Full mode device.
- Contains data lines TXD and RXD, hardware flow control lines RTS and CTS, status lines DTR, DCD and

RI.

- Serial port can be used for GPRS service and AT communication.
- Serial port supports the following baud rates:  
1200, 2400, 4800, 9600, 19200, 38400, 57600, 115200, 230400 and 460800bps
- Autobauding only supports the following baud rates:  
1200, 2400, 4800, 9600, 19200, 38400, 57600 and 115200bps
- The default setting is autobauding.

Autobauding allows SIM800H to automatically detect the baud rate of the host device. Pay more attention to the following requirements:

- **Synchronization between DTE and DCE:**

When DCE powers on with autobauding enabled, it is recommended to send "AT" or "at" or "aT" or "At" to synchronize the baud rate, until DTE receives the "OK" response, which means DTE and DCE are correctly synchronized. For more information please refer to AT command "AT+IPR".

- **Restrictions of autobauding operation:**

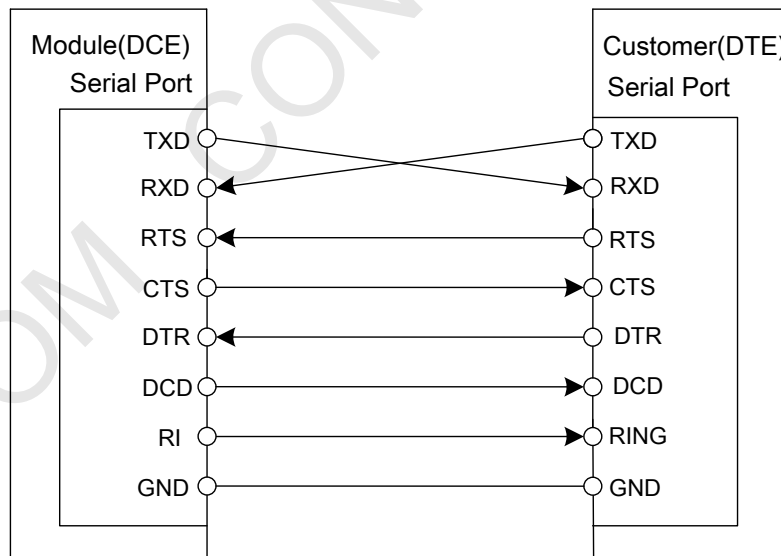
The DTE serial port must be set at 8 data bits, no parity and 1 stop bit.

The URC such as "RDY", "+CFUN: 1" and "+CPIN: READY" will not be reported.

*Note: Customer can use AT command "AT+IPR=x" to set a fixed baud rate and the setting will be saved to non-volatile flash memory automatically. After the configuration is set as fixed baud rate, the URC such as "RDY", "+CFUN: 1" and "+CPIN: READY" will be reported when SIM800H is powered on.*

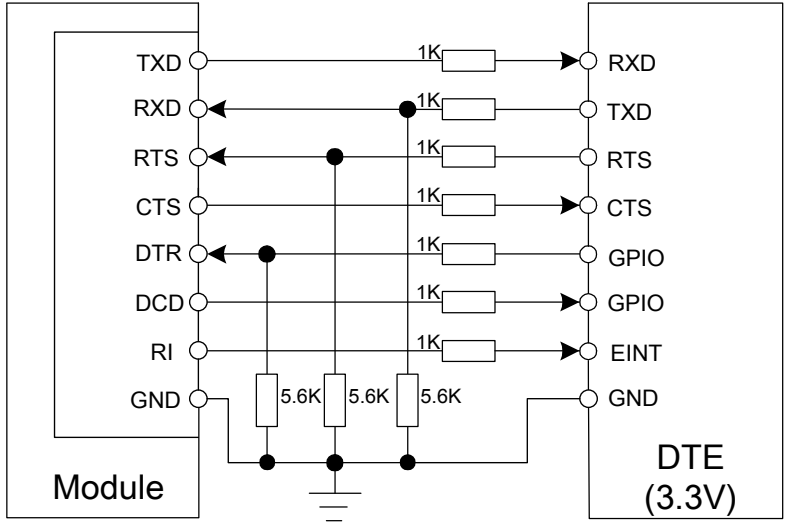
#### 4.5.2 Serial Interfaces

The following figure shows the connection between module and client (DTE).



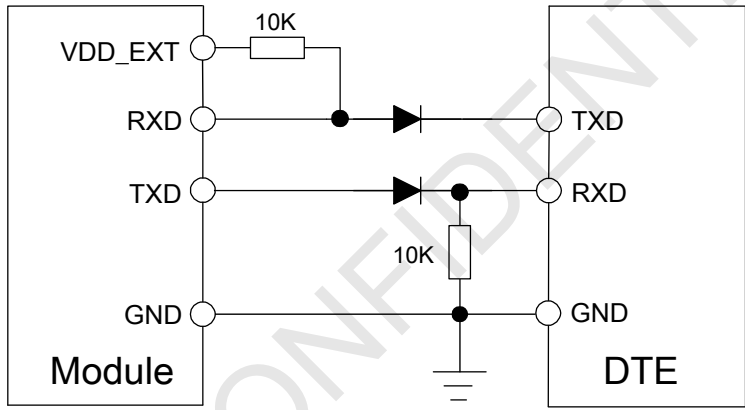
**Figure 20: Connection of the serial interfaces**

If the voltage of UART is 3.3V, the following reference circuits are recommended. If the voltage is 3.0V, please change the resistors in the following figure from 5.6K to 14K.



**Figure 21: Resistor matching circuit**

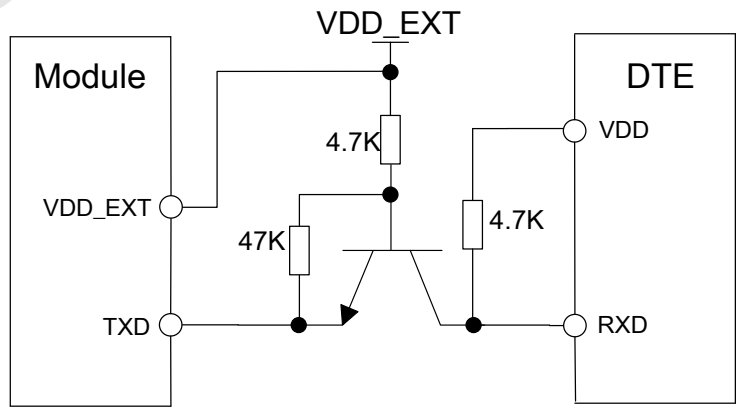
If the voltage of UART is 3V or 3.3V, the following reference circuits are recommended:



**Figure 22: Diode isolation circuit**

*Note: please make sure the minimum of client high limit should be less than 2.8V minus the diode drop.*

If the voltage of UART is 5V, the following reference circuits are recommended:



**Figure 23: TX level matching circuit**

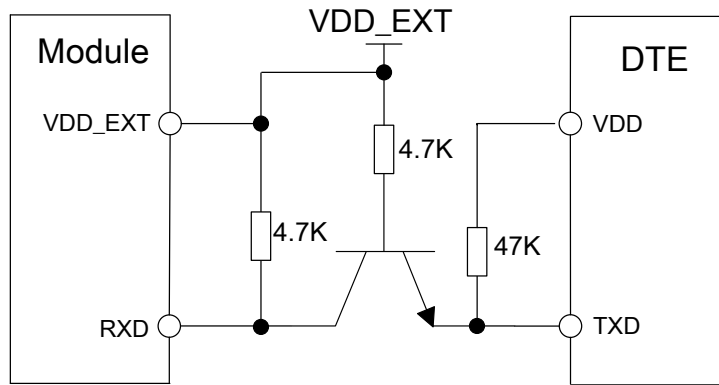


Figure 24: RX level matching circuit

*Note: When Figure 22, Figure 23 and Figure 24 are used for electrical level isolation, if customers use serial port to upgrade SW, please note VDD\_EXT has no voltage output during the upgrading process, LDO output could be used as VDD\_EXT in the figure, upgrading through USB port is recommended.*

### 4.5.3 Debug Interface

SIM800H could achieve software debug function through USB interface. When powering on the module, connect VBUS, USB\_DP, USB\_DN, and GND to PC, then install the driver following the prompts, a UART port could be recognized by PC, customer could achieve the software Debug with this UART port. SIMCom recommended the following connected diagram:

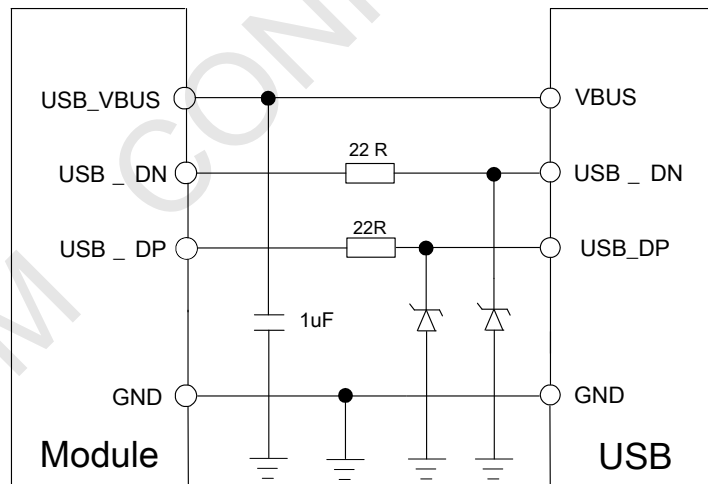


Figure 25: USB reference circuit

The TVS on USB data line should be less than 5pF, and traced by differential forms.

*Note: please reserve the USB interface or test point for the further debugging*

Table 11: VBUS operation voltage

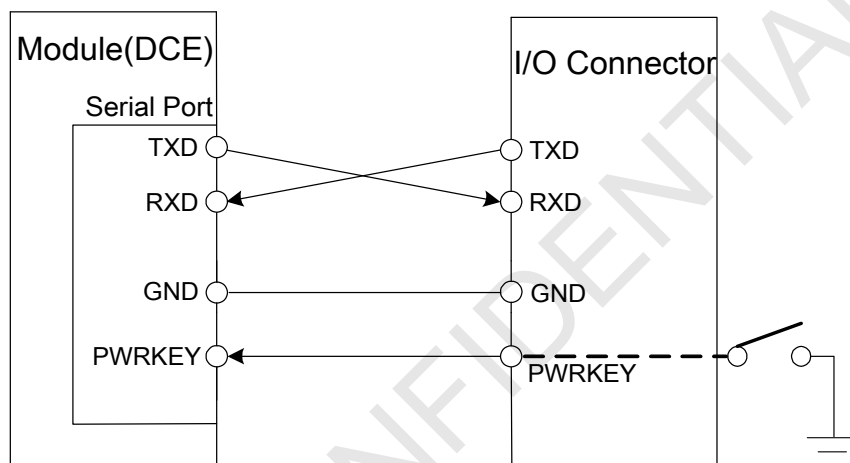
Pin	Min	Typ	Max	Unit
VBUS	4.3	5.0	7.0	V

#### 4.5.4 Software Upgrade

Customer could upgrade module's firmware through USB or UART interface.

If upgrading through USB interface, it is necessary to power on SIM800H first, then connect VBUS, USB\_DP, USB\_DN, and GND to PC. There is no need to operate PWRKEY pin in the whole procedure, when SIM800H detects VBUS and could communicate normally with USB\_DP and USB\_DN, it will enter USB download mode automatically.

If customer upgrades the software through UART interface, it is strongly recommended to lead the UART1\_TXD, UART1\_RXD, GND and PWRKEY pin to IO connector for the upgrading, and PWRKEY pin should connect to GND while upgrading. Refer to the following figure for debugging and upgrading software.



**Figure 26: Connection for software upgrading and debugging**

The UART interface supports the CMOS level. If customer connects the module to the computer, the level shifter should be added between the DCE and DTE.

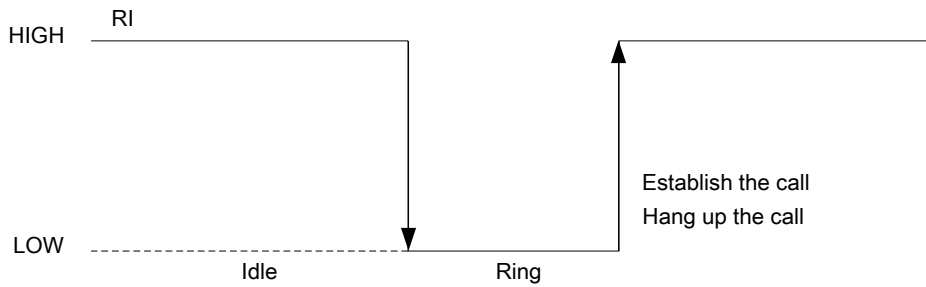
#### 4.6. RI Behaviors

**Table 12: RI behaviors**

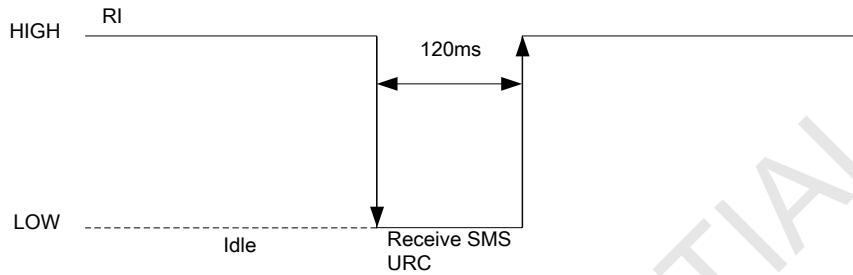
State	RI response
Standby	High
Voice call	The pin is changed to low. When any of the following events occur, the pin will be changed to high: (1) Establish the call (2) Hang up the call
SMS	The pin is changed to low, and kept low for 120ms when a SMS is received. Then it is changed to high.
URC	The pin is changed to low, and kept low for 120ms when some URCs are reported. Then it is changed to high. For more details, please refer to <i>document [10]</i> .

The behavior of the RI pin is shown in the following figure when the module is used as a receiver.



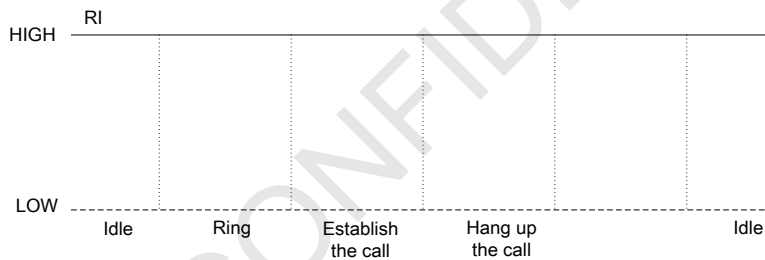


**Figure 27: RI behaviour of voice calling as a receiver**



**Figure 28: RI behaviour of URC or receive SMS**

However, if the module is used as caller, the RI will remain high. Please refer to the following figure.



**Figure 29: RI behaviour as a caller**

**4.7. Audio Interfaces**

SIM800H provides two analog inputs (MIC1P/1N; MIC2P/2N), which could be used for electret microphone. The module also provides two analog outputs (SPK1P/1N; SPK2P/2N).

**Table 13: Audio interface definition**

	Pin name	Pin number	Function
Main	MIC1P	52	Main Audio input positive
	MIC1N	12	Main Audio input negative
	SPK1P	53	Main Audio output positive
	SPK1N	13	Main Audio output negative
Secondary	MIC2P	9	Secondary Audio input positive
	MIC2N	10	Secondary Audio input negative
	SPK2P	51	Secondary Audio output positive
	SPK2N	11	Secondary Audio output negative

SPK1P/1N output can directly drive 32Ω receiver, SIM800H internal has class-AB audio amplifier, the following table is class-AB performance:

**Table 14: Performance of audio amplifier**

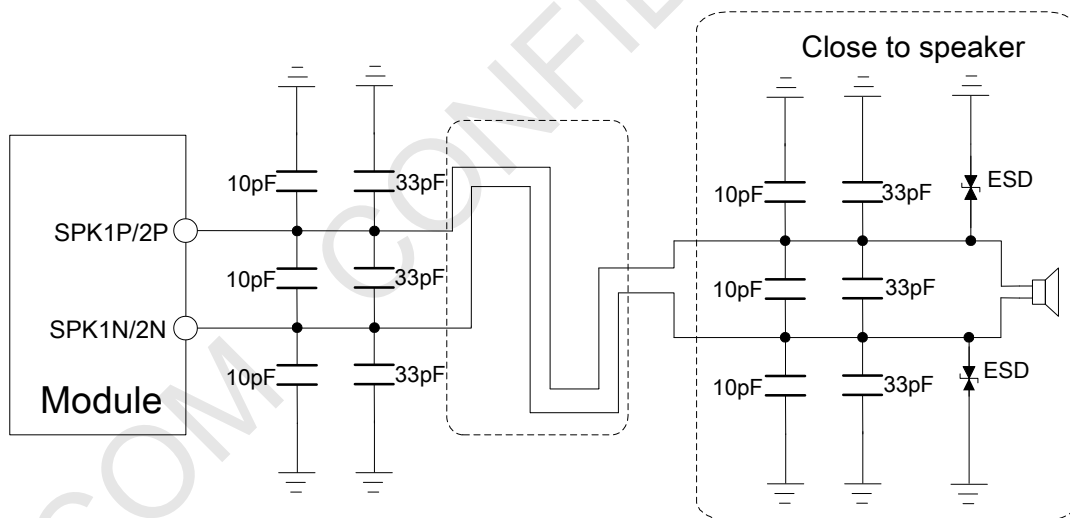
Conditions	Class-AB AMP
4.2V 8Ω THD+N=1%	0.87W
3.4V 8Ω THD+N=1%	0.53W
4.2V 8Ω THD+N=10%	1.08W
3.4V 8Ω THD+N=10%	0.65W

SPK2P/2N output can directly drive 8Ω speaker.

AT command “AT+CMIC” is used to adjust the input gain level of microphone. AT command “AT+SIDET” is used to set the side-tone level. In addition, AT command “AT+CLVL” is used to adjust the output gain level. For more details, please refer to *document [1]*.

In order to improve audio performance, the following reference circuits are recommended. The audio signals have to be layout according to differential signal layout rules as shown in following figures.

**4.7.1. Speaker Interfaces Configuration**



**Figure 30: Speaker reference circuit**

#### 4.7.2. Microphone Interfaces Configuration

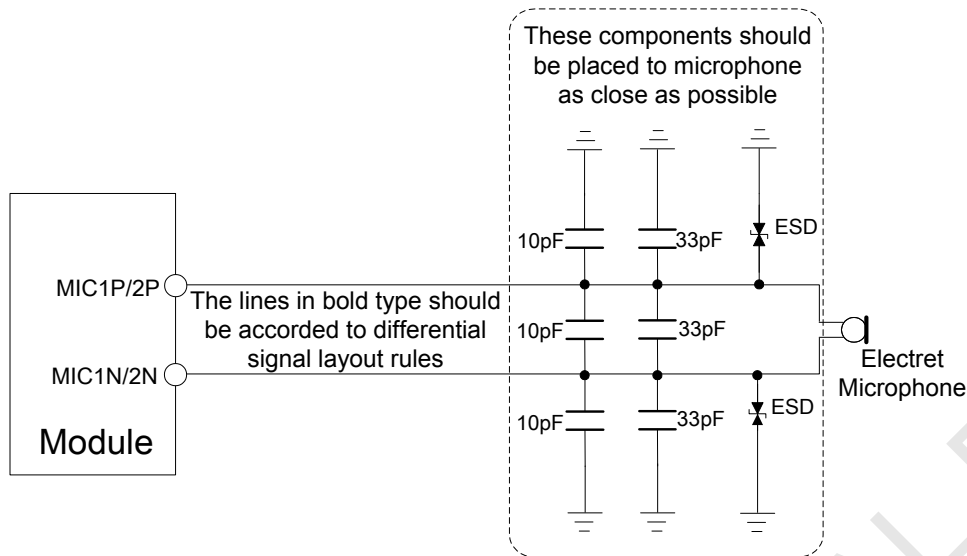


Figure 31: Speaker with amplifier reference circuit

#### 4.7.3. Audio Electronic Characteristic

Table 15: Microphone input characteristics

Parameter	Min	Typ	Max	Unit
Microphone biasing voltage		1.9	2.2	V
Working current			2.0	mA
Input impedance(differential)	13	20	27	KΩ
Idle channel noise			-67	dBm0
SINAD	Input level:-40dBm0	29		dB
	Input level:0dBm0		69	dB

Table 16: Audio output characteristics

Parameter	Conditions	Min	Typ	Max	Unit
Normal output	$R_L=32\ \Omega$ receiver	-	90	-	mW
	$R_L=8\ \Omega$ speaker	-	-	1080	mW

#### 4.7.4. TDD

Audio signal could be interferenced by RF signal. Coupling noise could be filtered by adding 33pF and 10pF capacitor to audio lines. 33pF capacitor could eliminate noise from GSM850/EGSM900MHz, while 10pF capacitor could eliminate noise from DCS1800/PCS1900Mhz frequency. Customer should develop this filter solution according to field test result.

GSM antenna is the key coupling interfering source of TDD noise. Thereat, pay attention to the layout of audio lines which should be far away from RF cable, antenna and VBAT pin. The bypass capacitor for filtering should be placed near module and another group needs to be placed near to connector.

Conducting noise is mainly caused by the VBAT drop. If audio PA was powered by VBAT directly, then there

will be some cheap noise from speaker output easily. So it is better to put big capacitors and ferrite beads near audio PA input.

TDD noise has something to do with GND signal. If GND plane is not good, lots of high-frequency noises will interference microphone and speaker over bypass capacitor. So a good GND during PCB layout could avoid TDD noise.

## 4.8. SIM Card Interface

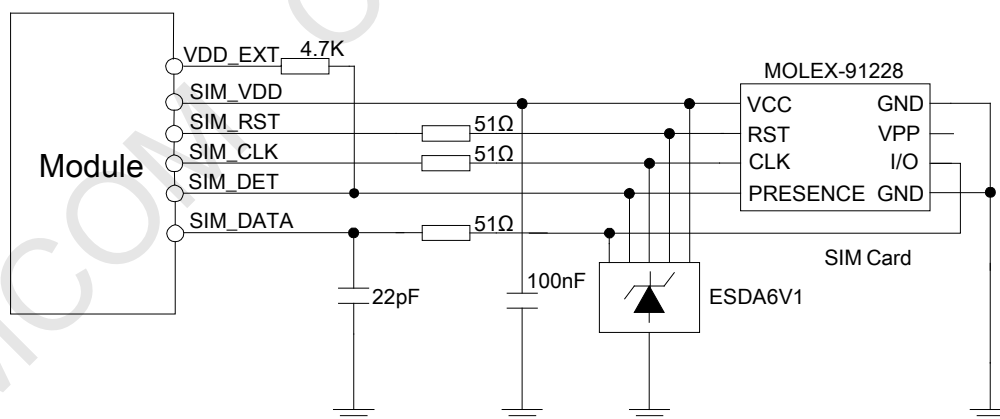
The SIM interface complies with the GSM Phase 1 specification and the new GSM Phase 2+ specification for FAST 64 kbps SIM card. Both 1.8V and 3.0V SIM card are supported. The SIM interface is powered from an internal regulator in the module.

### 4.8.1. SIM Card Application

**Table 17: SIM pin definition**

Pin name	Pin number	Function
SIM_VDD	16	Voltage supply for SIM card. Support 1.8V or 3V SIM card
SIM_DATA	14	SIM data input/output
SIM_CLK	55	SIM clock
SIM_RST	15	SIM reset
SIM_DET	54	SIM card detection

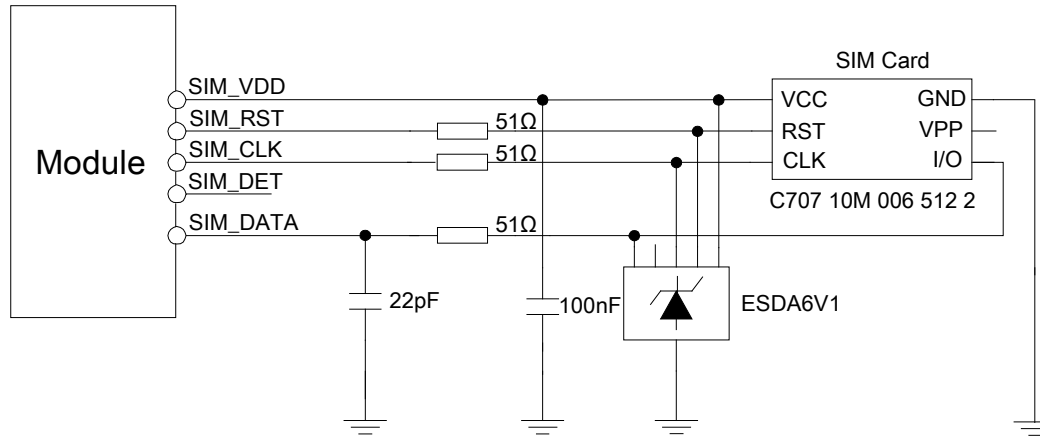
It is recommended to use an ESD protection component such as ST ([www.st.com](http://www.st.com)) ESDA6V1-5W6 or ON SEMI ([www.onsemi.com](http://www.onsemi.com)) SMF05C. That the SIM peripheral circuit should be close to the SIM card socket. The reference circuit of the 8-pin SIM card holder is illustrated in the following figure.



**Figure 32: Reference circuit of the 8-pin SIM card holder**

The SIM\_DET pin is used for detection of the SIM card hot plug in. Customer can select the 8-pin SIM card holder to implement SIM card detection function. AT command “AT+CSDT” is used to enable or disable SIM card detection function. For details of this AT command, please refer to *document [1]*.

If the SIM card detection function is not used, customer can keep the SIM\_DET pin open. The reference circuit of 6-pin SIM card holder is illustrated in the following figure.



**Figure 33: Reference circuit of the 6-pin SIM card holder**

#### 4.8.2. SIM Card Design Guide

SIM card signal could be interferenced by some high frequency signal, it is strongly recommended to follow these guidelines while designing:

- SIM card holder should be far away from GSM antenna
- SIM traces should keep away from RF lines, VBAT and high-speed signal lines
- The traces should be as short as possible
- Keep SIM card holder's GND connect to main ground directly
- Shielding the SIM card signal by ground well
- Recommended to place a 100nF capacitor on SIM\_VDD line and keep close to the SIM card holder
- Add some TVS which parasitic capacitance should not exceed 50pF
- Add 51Ω resistor to (SIM\_RST/SIM\_CLK/SIM\_DATA) signal could enhance ESD protection

#### 4.8.3. Design Considerations for SIM Card Holder

For 8 pins SIM card holder, SIMCom recommends to use Molex 91228. Customer can visit <http://www.molex.com> for more information about the holder.

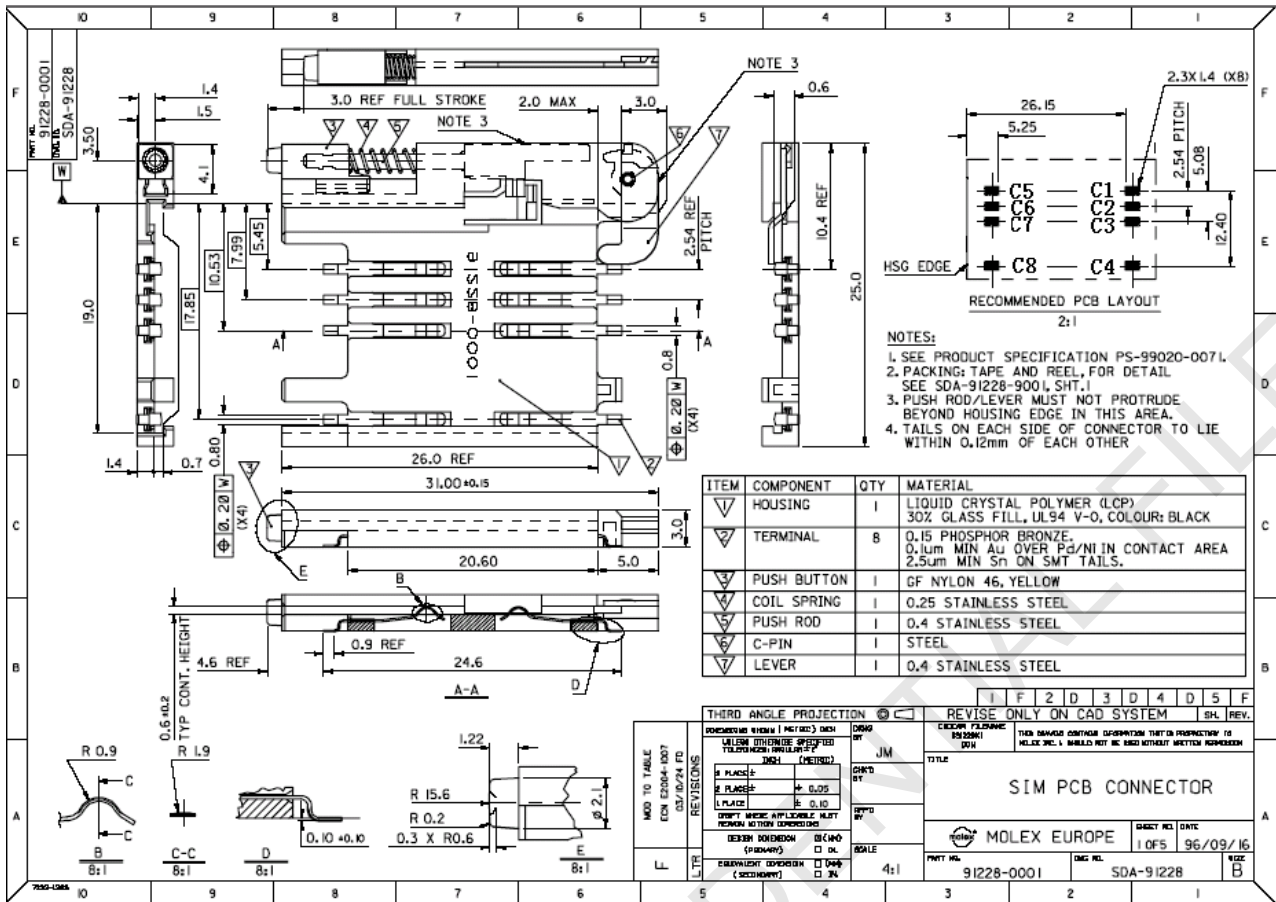


Figure 34: Molex 91228 SIM card holder

Table 18: Pin description (Molex SIM card holder)

Pin name	Signal	Description
C1	SIM_VDD	SIM card power supply
C2	SIM_RST	SIM card reset
C3	SIM_CLK	SIM card clock
C4	GND	Connect to GND
C5	GND	Connect to GND
C6	VPP	Not connect
C7	SIM_DATA	SIM card data I/O
C8	SIM_DET	Detect SIM card presence

For 6-pin SIM card holder, SIMCom recommends to use Amphenol C707 10M006 512 .Customer can visit <http://www.amphenol.com> for more information about the holder.

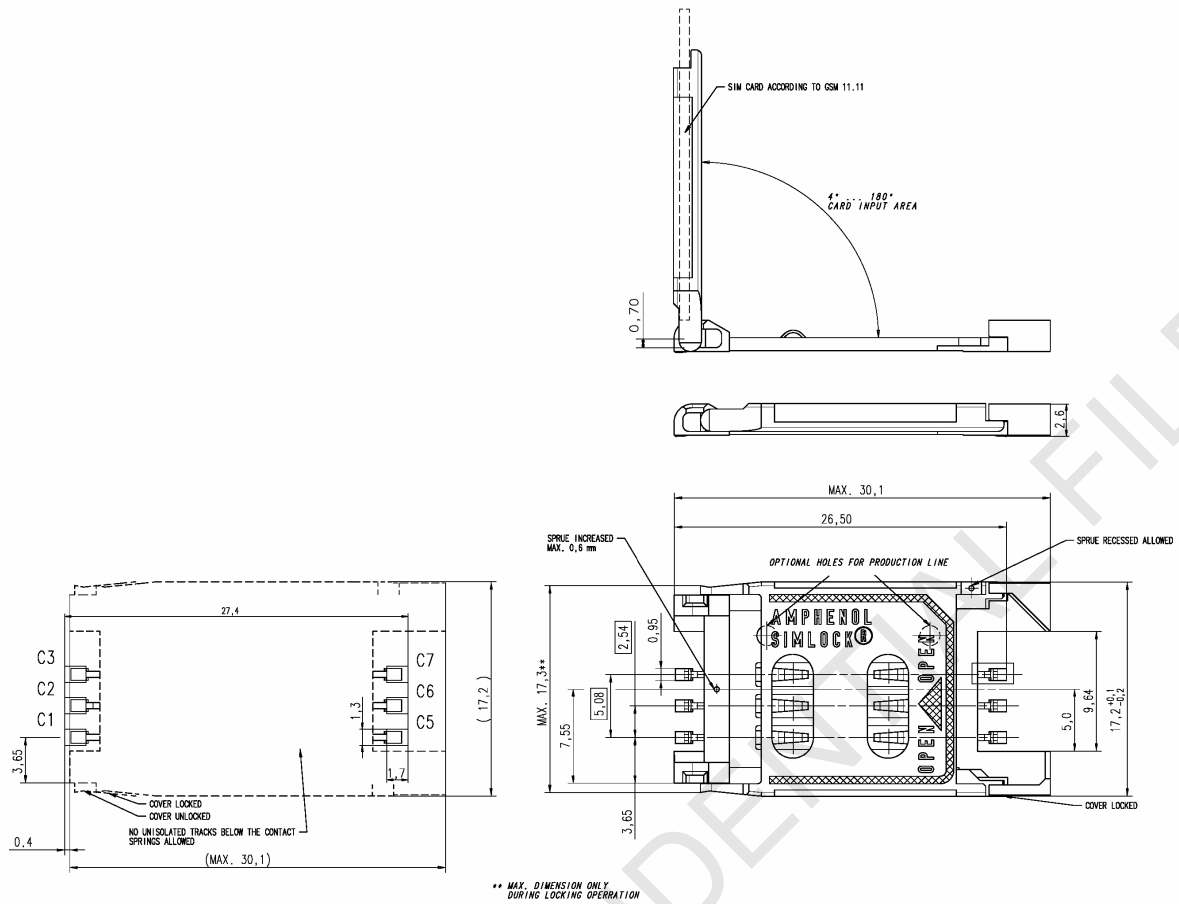


Figure 35: Amphenol C707 10M006 512 SIM card holder

Table 19: Pin description (Amphenol SIM card holder)

Pin name	Signal	Description
C1	SIM_VDD	SIM card power supply
C2	SIM_RST	SIM card reset
C3	SIM_CLK	SIM card clock
C5	GND	Connect to GND
C6	VPP	Not connect
C7	SIM_DATA	SIM card data I/O

Note: Every time plug SIM card interval advice is greater than 2s. Otherwise may not be able to correct detection.

#### 4.9. PCM Interface

SIM800H provides a hardware PCM interface:

Table 20: PCM pin definition

Pin name	Pin number	Description
PCM_CLK	29	PCM clock

PCM_OUT	30	PCM data output
PCM_SYNC	65	PCM synchrony
PCM_IN	66	PCM data input

SIM800H PCM interface only supply master mode, data length is 16 bits (linear), PCM clock rate is 256kHz.

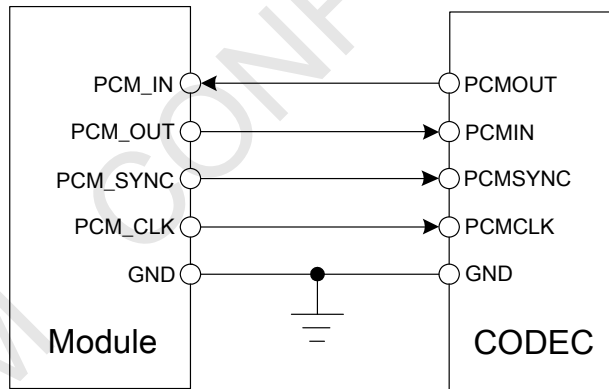
**Table 21: PCM specification**

Parameter	Specification
Line Interface Format	Linear(Fixed)
Data length	16bits(Fixed)
PCM Clock/Sync Source	Master Mode(Fixed)
PCM Clock Rate	256kHz(Fixed)
PCM Sync Format	Short sync/Long sync both support
Zero Padding/Sign extension	Zero Padding(Fixed)
Data Ordering	MSB/LSB both support

*Note: Customer can use AT command control PCM interface. For detail, please refer to document [1].*

#### 4.9.1. PCM reference circuit

Refer to the following figure for PCM design:



**Figure 36: PCM reference circuit**



### 4.10. Keypad Interface

The keypad interface consists of 5 keypad column outputs and 5 keypad row inputs. with total  $5*5*2$ , which is 50 keys. Module has two connections, which supports 25 keys and another supports 50 keys.

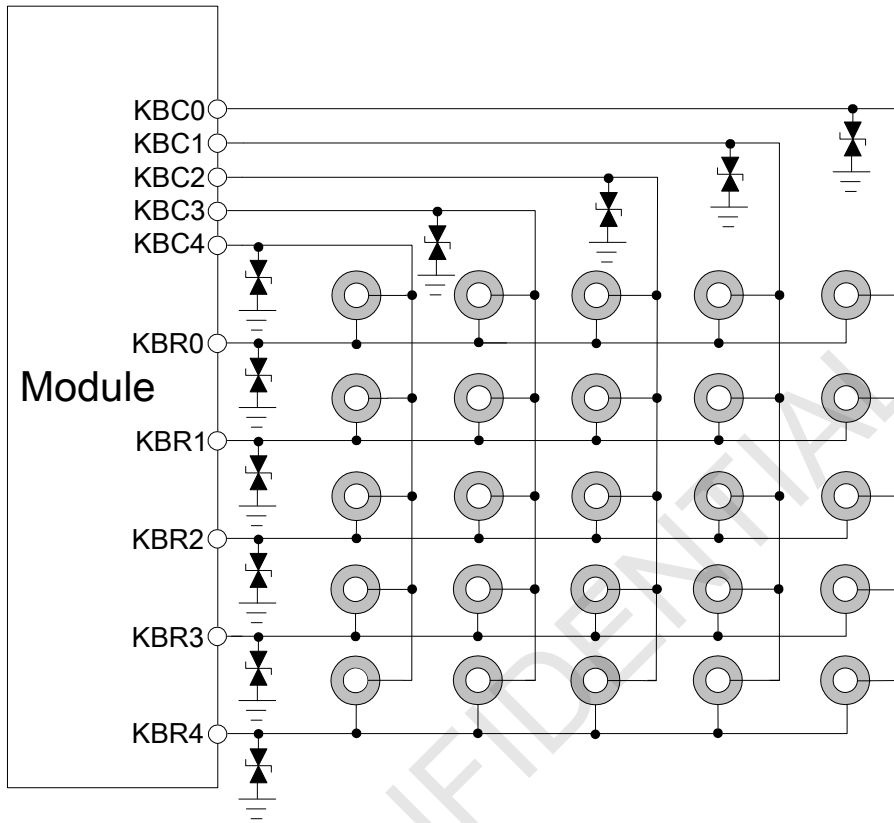


Figure 37: 25 keys reference circuit

*Note: According to the traditional 5\*5 to design buttons, when there is spare KBC or KBR, customer can execute AT command to define as GPIO for details please see the relevant manuals.*

Module supports a new key connection, can support 50 keys, which meets full keyboard demand, the connection diagram is as following:

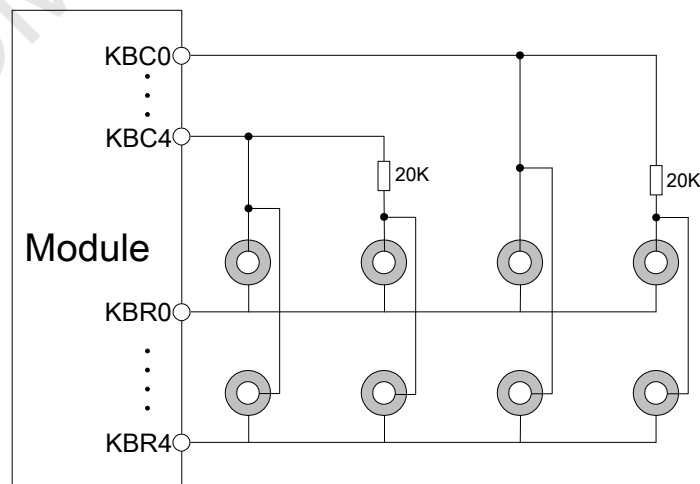
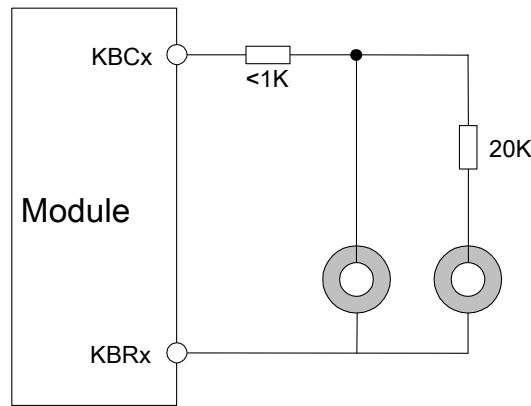


Figure 38: 50 keys reference circuit

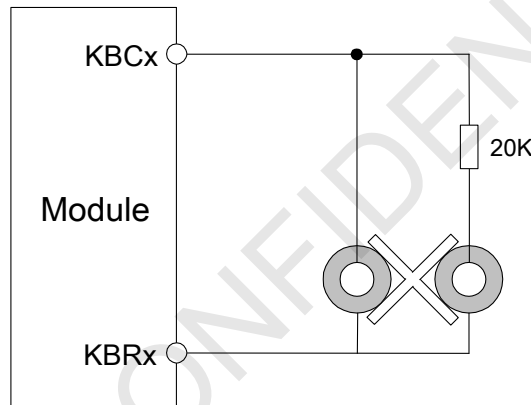
*Note: Do not change the 20KΩ resistor in the diagram.*

Customer could cascade a less than 1K resistor to enhance the ESD performance, the connection diagram is as following:



**Figure 39: Keypad reference circuit**

Whether using a 5\*5 keys or 5\*5\*2 keys, the module can also detect the two buttons pressed. But when using a 5\*5\*2 button, the same row, column two buttons pressed at the same time can't be detected, as shown below:



**Figure 40: Keypad detected**

**Table 22: Pin definition of the keypad interface**

Pin name	Pin number	Function	Default state
KBC0	20	Keypad matrix column	Pull up
KBC1	25		Pull up
KBC2	22		Pull up
KBC3	21		Pull up
KBC4	24		Pull up
KBR0	62	Keypad matrix row	Pull down
KBR1	60		Pull down
KBR2	61		Pull down
KBR3	23		Pull down
KBR4	63		Pull down

*Note: Please be sure to increase the ESD protection devices in product design phase, and make sure have ESD protection devices in the final product.*

### 4.11. I2C Bus

The SIM800H provides an I2C interface which is only used in the embedded AT application.

- The highest data rate is 400kbit/s
- Automatic start and stop bits
- Generated response and confirmation automatically
- Application hardware I2C protocol

**Table 23: Pin definition of the I2C**

Pin name	Pin number	Description
SCL	74	I2C serial bus clock
SDA	75	I2C serial bus data

Notes:

1. This function is not supported in the standard firmware. If customer wants this function, the firmware must be customized. Please contact SIMCom for more details.

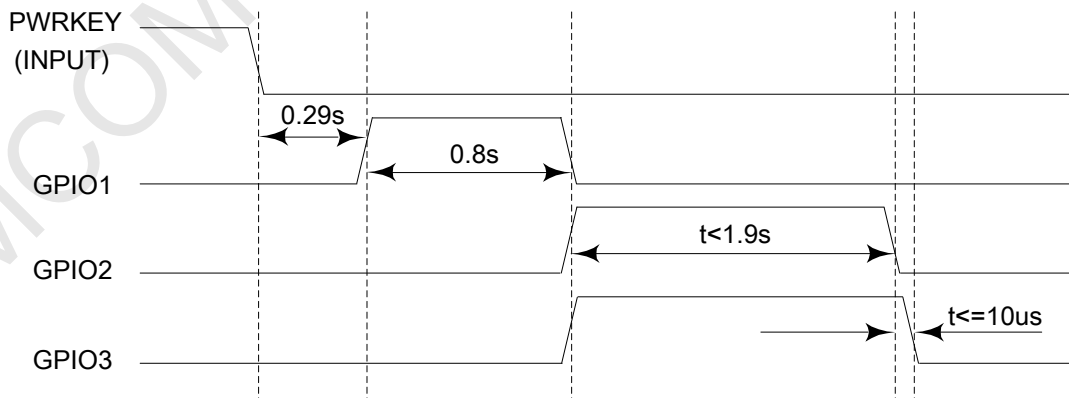
2. If customers design I2C please pull up to VDD\_EXT.

### 4.12. General Purpose Input/Output (GPIO)

SIM800H provides 3 GPIO pins. The output voltage level of the GPIO can be set by AT command “AT+SGPIO”. The input voltage level of the GPIO can also be read by AT command “AT+SGPIO”. For more details, please refer to *document [1]*.

**Table 24: Pin definition of the GPIO**

Pin name	Pin number	Reset state
GPIO1	3	Refer to Figure 41
GPIO2	27	Refer to Figure 41
GPIO3	28	Refer to Figure 41



**Figure 41: GPIO timing sequences**

### 4.13. ADC

**Table 25: Pin definition of the ADC**

Pin name	Pin number	Description
ADC	50	Analog voltage input

SIM800H provides an auxiliary ADC, which can be used to measure the voltage. Customer can use AT command “AT+CADC” to read the voltage value. For details of this AT command, please refer to *document [1]*.

**Table 26: ADC specification**

Parameter	Min	Typ	Max	Unit
Voltage range	0	-	2.8	V
ADC Resolution	-	10	-	bits
Sampling rate	-	-	1.0833	MHz
ADC precision		10	30	mV

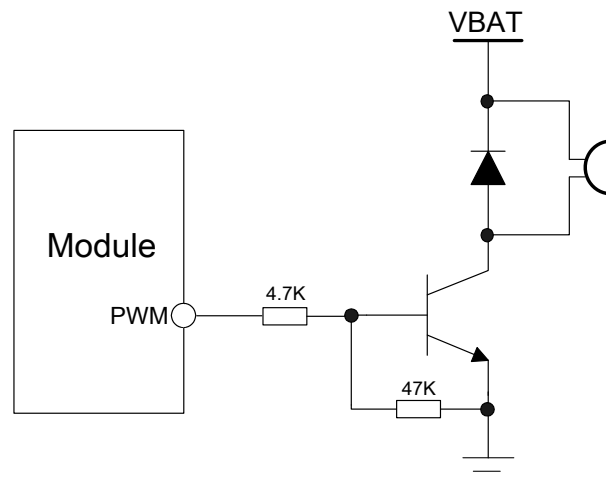
### 4.14. PWM

**Table 27: Pin definition of the PWM**

Pin name	Pin number	Description
PWM	26	PWM signal

SIM800H provides a PWM which can be used to drive a vibrator, and a backlight LED for display or keyboard. PWM output frequency varies from 0~2kHz. Two 7-bit unsigned binary parameters are used for the output period and for the duty cycle. AT command “AT + SPWM” is used to set the output period and duty cycle of the PWM. For details, please refer to *document [1]*.

A typical recommended circuit of the PWM driver buzzer is shown in the following figure.



**Figure 42: Reference circuit of PWM driver buzzer**

**Table 28: Buzzer characteristics**

Parameter	Min	Typ	Max	Unit
Working voltage	2.5	2.8	2.9	V
Working current			16	mA

*Note: PWM pin must be kept at low power level when module is in the power on procedure.*

#### 4.15. Network Status Indication

**Table 29: Pin definition of the NETLIGHT**

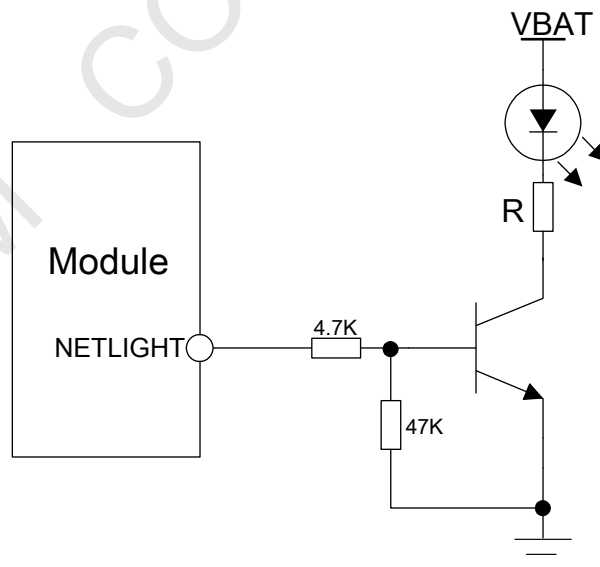
Pin name	Pin number	Description
NETLIGHT	64	Network Status Indication

The NETLIGHT pin can be used to drive a network status indication LED. The status of this pin is listed in following table:

**Table 30: Status of the NETLIGHT pin**

Status	SIM800H behavior
Off	SIM800H is not running
64ms On/ 800ms Off	SIM800H not registered the network
64ms On/ 3000ms Off	SIM800H registered to the network
64ms On/ 300ms Off	GPRS communication is established

Reference circuit is recommended in the following figure:


**Figure 43: Reference circuit of NETLIGHT**

#### 4.16. Operating Status Indication

The pin4 is for operating status indication of the module. The pin output is high when module is powered on, and output is low when module is powered down.

**Table 31: Pin definition of the STATUS**

Pin name	Pin number	Description
STATUS	4	Operating status indication

Note: For timing about STATUS, please reference to the chapter “4.2 power on/down scenarios”

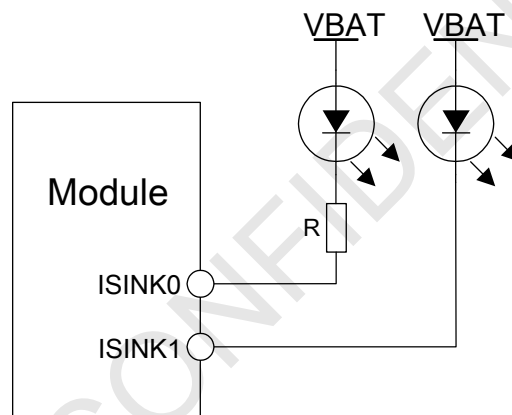
#### 4.17. LED Interface

SIM800H provides two LED driver pin. The two pin are open-drain output.

**Table 32: Pin definition of the LED**

Pin name	Pin number	Description
ISINK0	47	Sink current for LCM module
ISINK1	46	Sink current for keypad LED

Reference circuit is recommended in the following figure:


**Figure 44: LED driver reference circuit**
**Table 33: ISINK specification**

Pin name	Min	Typ	Max	Unit
ISINK0	-		24	mA
ISINK1	60	-	100	mA

Note: Isink0 provide 6-current-level steps of up to 24mA.

#### 4.18. RF Synchronization Signal

The synchronization signal serves to indicate growing power consumption during the transmit burst. The signal is generated by the RF\_SYNC pin.

**Table 34: Definition of the RF\_SYNC pin**

Pin name	Pin number	Description
RF_SYNC	5	Transmit synchronization signal

The timing of the synchronization signal is shown below. High level of the RF\_SYNC pin indicates increased power consumption during transmission.

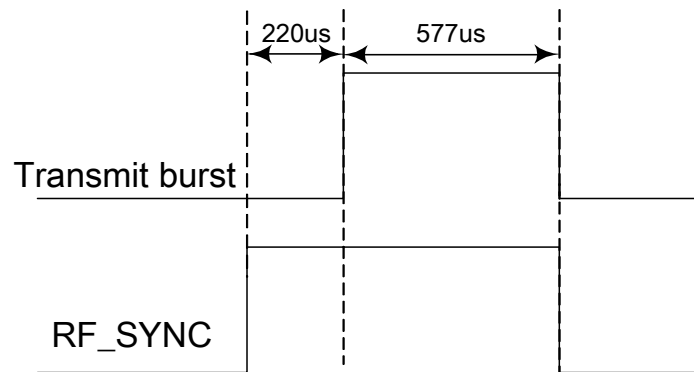


Figure 45: RF\_SYNC signal during transmit burst

### 4.19. Antenna Interface

There are three antenna ports for SIM800H, GSM antenna port named GSM\_ANT, Bluetooth antenna port named BT\_ANT and FM antenna port named FM\_ANTP/FM\_ANTN, The RF interface of the three antenna ports has an impedance of 50Ω.

- The input impedance of the antenna should be 50Ω, and the VSWR should be less than 2.
- It is recommended that the GSM antenna and the BT antenna should be placed as far as possible.
- The isolations of the three antenna should be bigger than 30dB

*NOTE: About the RF trace layout please refer to “AN\_SMT Module\_RF\_Reference Design\_Guide”.*

#### 4.19.1. GSM Antenna Interface

There is a GSM antenna pad named GSM\_ANT for SIM800H, the connection of the antenna must be decoupled from DC voltage. This is necessary because the antenna connector is DC coupled to ground via an inductor for ESD protection.

The external antenna must be matched properly to achieve best performance, so the matching circuit is necessary, the connection is recommended as following:

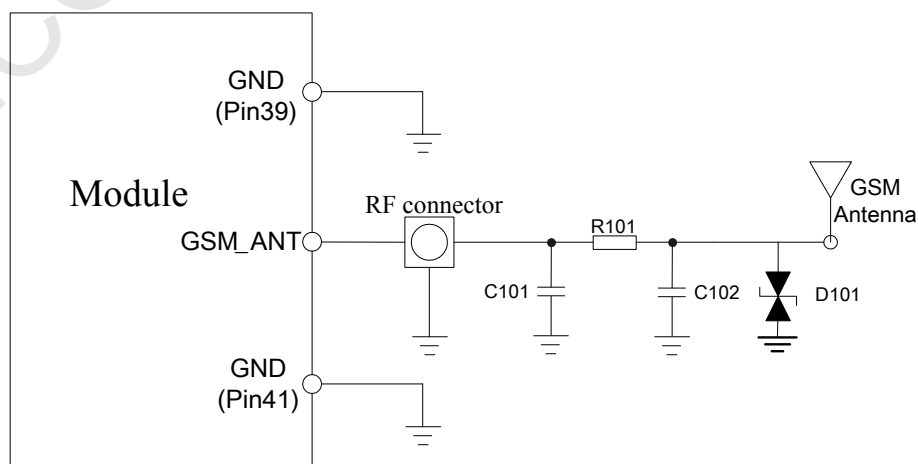


Figure 46: GSM antenna matching circuit

R101, C101, C102 are the matching circuit, the value should be defined by the antenna design. Normally R101 is 0Ω, C101 and C102 are not mounted. The RF connector is used for conduction test. If the space between RF pin and antenna is not enough, the matching circuit should be designed as in the following figure:

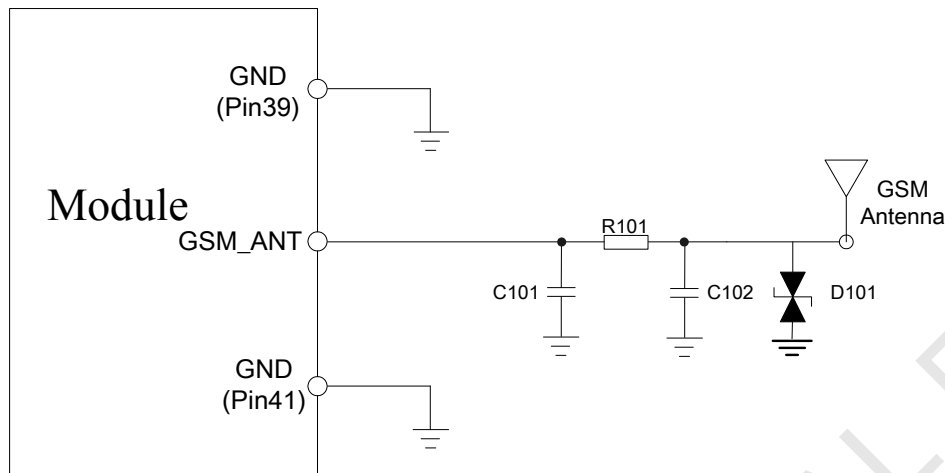


Figure 47: GSM simple antenna matching circuit

Normally R101 is 0Ω, C101 and C102 are not mounted.

D101 in Figure 46 and Figure 47 is used for ESD to protect antenna. In order to avoid damaging the module, TVS can be used. The TVS suggested can refer to Table 35.

Table 35: Recommended transient voltage suppressor

	Vendor	Part number	Packages
1	Marata	LXES03AAA1-154	0201
2	Marata	LXES15AAA1-153	0402

#### 4.19.2. Bluetooth Antenna Interface

The SIM800H module provides a Bluetooth antenna pad named BT\_ANT.

The external antenna must be matched properly to achieve best performance, so the matching circuit is necessary, the connection is recommended as in the following figure:

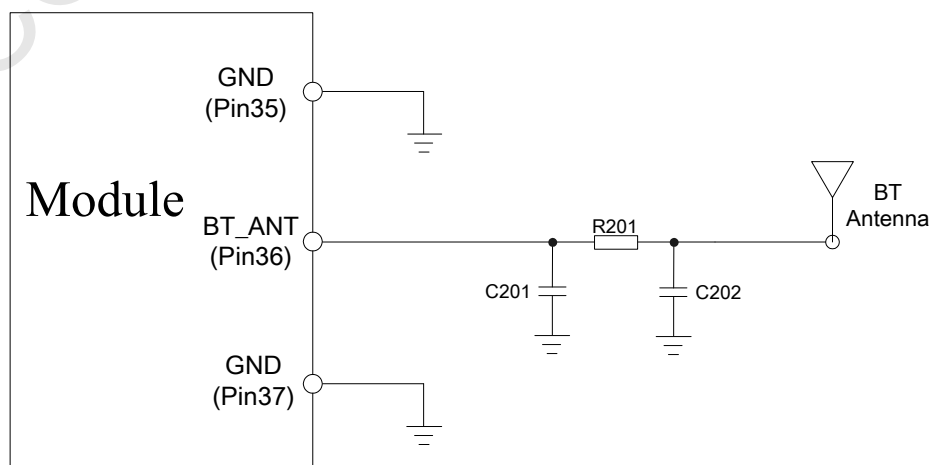


Figure 48: Bluetooth antenna matching circuit



R201, C201, C202 are the matching circuit, the value should be defined by the antenna design. Normally R201 is 1.2nH, C202 is 1.5pF and C201 are not mounted.

There are some suggestions for placing components and RF trace lying for GSM and Bluetooth RF traces:

- The RF connector is used for conducted test, so keep it as close to pin GSM\_ANT as possible;
- Antenna matching circuit should be closed to the antenna;
- Keep the RF traces as 50Ω;
- The RF traces should be kept far away from the high frequency signals and strong disturbing source.

#### 4.19.3. FM Antenna Interface

The module provides 2 FM antenna pad named FM\_ANTP and FM\_ANTN, these are difference signal. The FM antenna interface circuit is recommended as following:

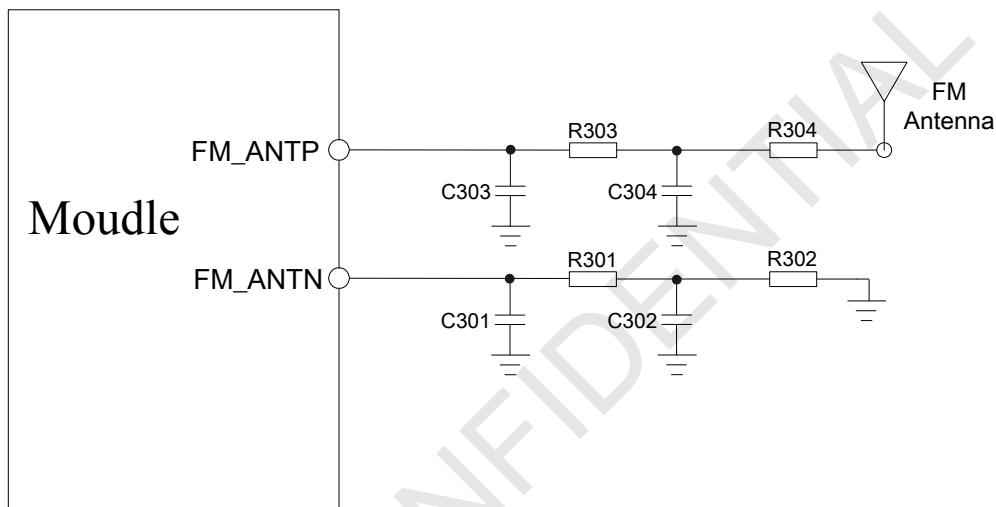


Figure 49: FM antenna matching circuit

Normally, R301\R302\R303\R304 are 0Ω, C301\C302\C303\C304 are not mounted.

The earphone is often used for FM antenna, as an example, the pin GND of the 3.5mm earphone is connected to the FM interface. The circuit is recommended as following:

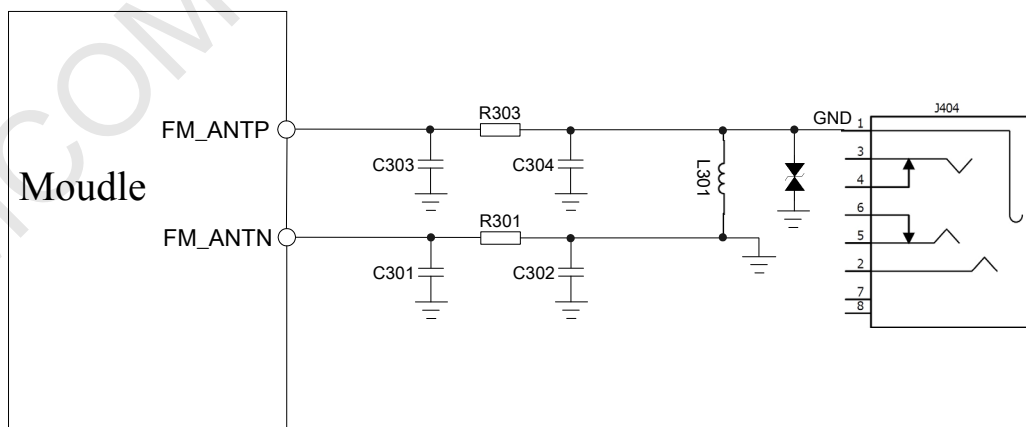


Figure 50: GND pin of the earphone use to be the FM antenna interface

Normally, R301\R303 are 0Ω, C301\C302\C303\C304\L301 are not mounted.

## 5. PCB Layout

Usually, most electronic products with good performance are based on good PCB layout. A bad PCB layout will lead to lots of issues, like TDD noise, SIM card not be detected, etc. the final solution for these problems is to redo PCB layout. Making good PCB layout at beginning will save develop schedule and cost as well.

This section will give some guidelines on PCB layout, in order to eliminate interfere or noise by greatest degree, and save product development period.

### 5.1 Pin Assignment

Before PCB layout, we should learn well about pin assignment in order to get reasonable layout with so many external components. Following figure is the overview of pin assignment of the module.

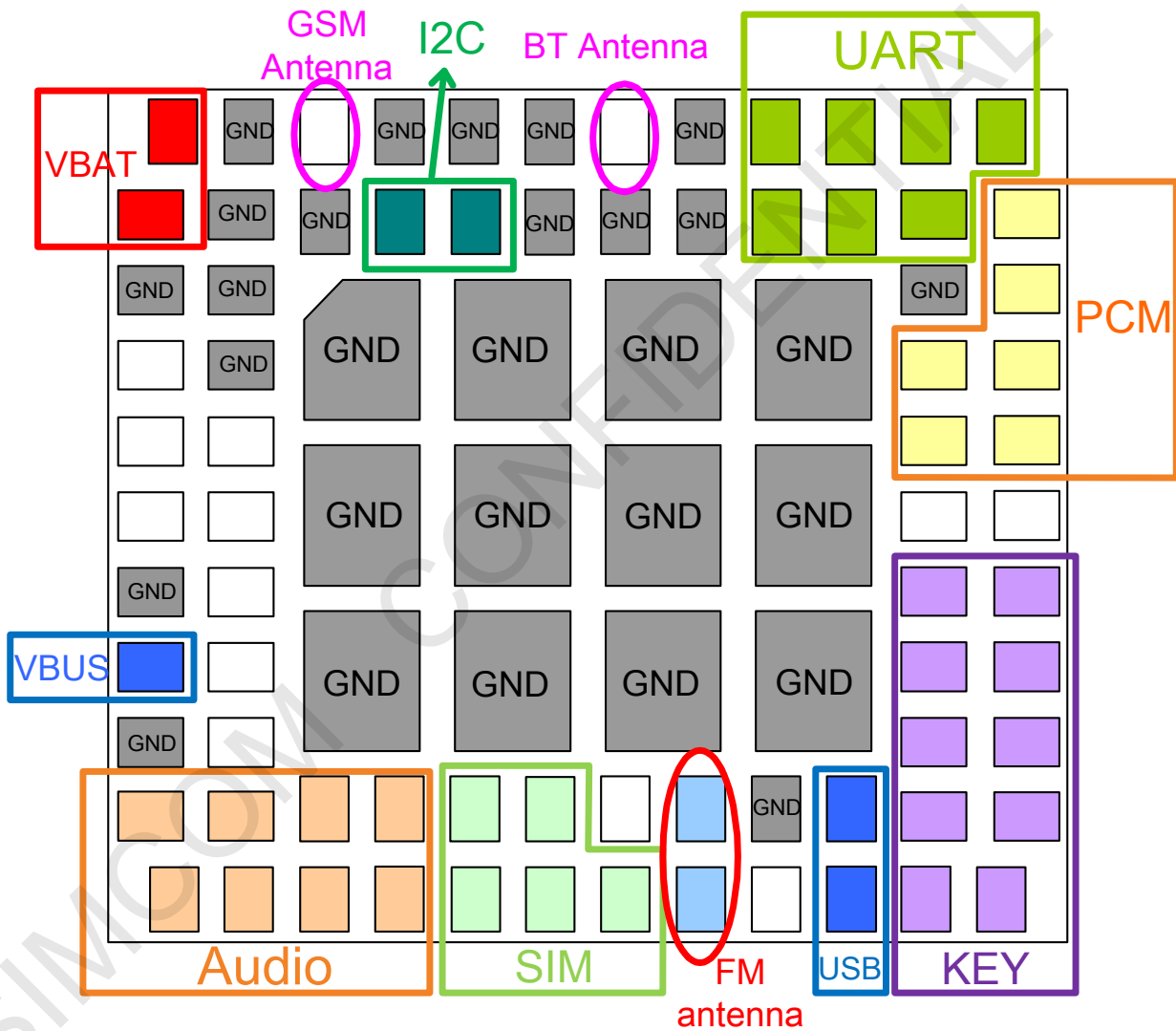


Figure 51: Pin assignment

## 5.2 Principle of PCB Layout

During layout, attention should be paid to the following interfaces, like Antenna, power supply, SIM card interface, audio interface, and so on.

### 5.2.1 Antenna Interface

- The length of trace between pin output and connector should be as short as possible;
- Do not trace RF signal over across the board;
- The RF signal should be far away from SIM card, power ICs.

### 5.2.2. Power Supply

- Not only VBAT but also return GND are very important in layout;
- The positive line of VBAT should be as short and wide as possible;
- The correct flow from source to VBAT pin should go through Zener diode then huge capacitor;
- Pin 2, Pin 43, Pin 44 and Pin45 are GND signals, and shortest layout to GND of power source should be designed;
- There are 12 GND pads in middle of module; these pads could enhance the GND performances. On the upper layer of these pads, do not trace any signal if possible.

### 5.2.3 SIM Card Interface

- SIM card holder has no anti-EMI component inside. Thus SIM card interface maybe interfered, please pay more attention on this interface during layout;
- Ensure SIM card holder is far way from antenna or RF cable inside;
- Put SIM card holder near the module, as nearer as possible;
- Add ESD component to protect SIM\_CLK, SIM\_DATA, SIM\_RST and SIM\_VDD signals which should be far away from power and high-speed-frequency signal.

### 5.2.4 Audio Interface

- The signal trace of audio should far away from antenna and power;
- The audio signal should avoid to parallel with VBAT trace.

### 5.2.5 Others

It is better to trace signal lines of UART bunched, as well as signals of USB.

### 5.3 Recommended PCB Layout

Based on above principles, recommended layout is shown in the following illustration.

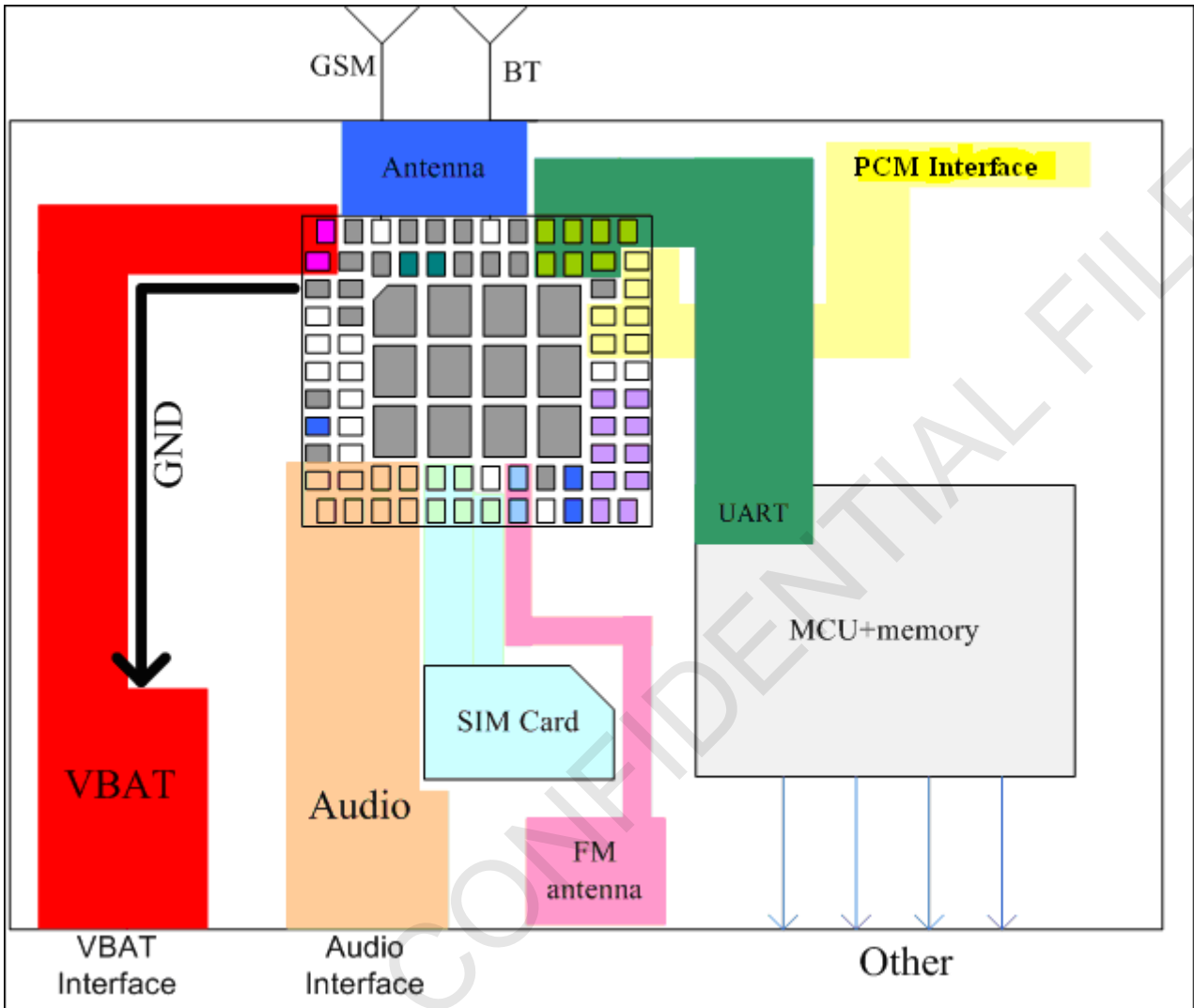


Figure 52: Recommended PCB layout

## 6. Electrical, Reliability and Radio Characteristics

### 6.1 Absolute Maximum Ratings

The absolute maximum ratings stated in following table are stress ratings under non-operating conditions. Stresses beyond any of these limits will cause permanent damage to SIM800H.

**Table 36: Absolute maximum ratings**

Symbol	Min	Typ	Max	Unit
V <sub>BAT</sub>	-	-	4.5	V
Current	0	-	2.0	A
V <sub>BUS</sub>	-	-	12	V
I <sub>I</sub> *	-	4	16	mA
I <sub>O</sub> *	-	4	16	mA

\*These parameters are for digital interface pins, such as keypad, GPIO, I2C, UART, and PCM.

### 6.2 Recommended Operating Conditions

**Table 37: Recommended operating conditions**

Symbol	Parameter	Min	Typ	Max	Unit
V <sub>BAT</sub>	Power supply voltage	3.4	4.0	4.4	V
V <sub>BUS</sub>	USB operating voltage	4.3	5.0	7	V
T <sub>OPER</sub>	Operating temperature	-40	+25	+85	°C
T <sub>STG</sub>	Storage temperature	-45		+90	°C

### 6.3 Digital Interface Characteristics

**Table 38: Digital interface characteristics**

Symbol	Parameter	Min	Typ	Max	Unit
V <sub>IH</sub>	High-level input voltage	2.1	-	3.1	V
V <sub>IL</sub>	Low-level input voltage	-0.3	-	0.7	V
V <sub>OH</sub>	High-level output voltage	2.4	2.8	-	V
V <sub>OL</sub>	Low-level output voltage	-	-	0.4	V

*Note: These parameters are for digital interface pins, such as keypad, GPIO, I2C, UART, and PCM.*

## 6.4 SIM Card Interface Characteristics

**Table 39: SIM card interface characteristics**

Symbol	Parameter	Min	Typ	Max	Unit
$I_{IH}$	High-level input current	-1.0	-	1.0	$\mu A$
$I_{IL}$	Low-level input current	-1.0	-	1.0	$\mu A$
$V_{IH}$	High-level input voltage	1.4	-	-	V
		2.4	-	-	V
$V_{IL}$	Low-level input voltage	-	-	0.27	V
		-	-	0.4	V
$V_{OH}$	High-level output voltage	1.62	-	-	V
		2.7	-	-	V
$V_{OL}$	Low-level output voltage	-	-	0.36	V
		-	-	0.4	V

## 6.5 SIM\_VDD Characteristics

**Table 40: SIM\_VDD characteristics**

Symbol	Parameter	Min	Typ	Max	Unit
$V_O$	Output voltage	-	3.0	-	V
		-	1.8	-	
$I_O$	Output current	-	-	10	mA

## 6.6 VDD\_EXT Characteristics

**Table 41: VDD\_EXT characteristics**

Symbol	Parameter	Min	Typ	Max	Unit
$V_O$	Output voltage	2.7	2.8	2.9	V
$I_O$	Output current	-	-	50	mA

## 6.7 VRTC Characteristics

**Table 42: VRTC characteristics**

Symbol	Description	Min	Typ	Max	Unit
$V_{RTC-IN}$	VRTC input voltage	1.2	2.8	3.0	V
$I_{RTC-IN}$	VRTC input current	-	3.0	5.0	$\mu A$
$V_{RTC-OUT}$	VRTC output voltage	-	2.8	-	V
$I_{RTC-OUT}$	VRTC output current	-	-	2.0	mA

## 6.8 Current Consumption (VBAT=3.8V)

**Table 43: Current consumption**

Symbol	Parameter	Conditions	Min	Typ	Max	Unit
VBAT	Voltage		3.4	4.0	4.4	V
	Power drop	PCL=5			350	mV
	Voltage ripple	PCL=5			50	mV
		@ f<200kHz @ f>200kHz			2.0	mV
IVBAT	Average current	Power down mode		150	200	uA
		Sleep mode (AT+CFUN=1): ( BS-PA-MFRMS=9 )		1.04		mA
		( BS-PA-MFRMS=5 )		1.14		mA
		( BS-PA-MFRMS=2 )		1.57		mA
		Idle mode (AT+CFUN=1): EGSM900		17.38		mA
		Voice call (PCL=5): GSM850		221.11		mA
		EGSM900		238.44		mA
		DCS1800		157.48		mA
		PCS1900		159.22		mA
		Data mode(1Rx,4Tx): GSM850		491.79		mA
		EGSM900		529.84		mA
		DCS1800		333.16		mA
		PCS1900		336.28		mA
		Data mode (3Rx,2Tx): GSM850		359.75		mA
		EGSM900		385.73		mA
		DCS1800		250.54		mA
		PCS1900		251.30		mA
		Data mode (4Rx,1Tx): GSM850		233.87		mA
		EGSM900		249.85		mA
		DCS1800		174.13		mA
		PCS1900		174.94		mA
IMAX	Peak current	During Tx burst			2.0	A

*Note: In above table the current consumption value is the typical one of the module tested in laboratory. In the mass production stage, there may be differences among each individual.*

**Table 44: Bluetooth characteristics**

Terms	Contents			
Bluetooth specification	Version3.0			
Channel spacing	1MHz			
Number of RF channel	79			
Power class	1.5			
Operation mode (Rx/Tx)	Time division multiplex either transmit or receive Frequency hopping after one Rx/Tx cycle			
Items	Min	Typ	Max	Unit
1. Output Power	5.5	7.5	10	dBm
2. Frequency range (Rx/Tx)	2402 - 2480			MHz
3. -20dB bandwidth	-	0.8	1	MHz
4. Adjacent Channel Power				
5.1 [M-N] = 2		-46	-20	dBm
5.2 [M-N] > 2		-51	-40	dBm
6. Modulation characteristics				
6.1 Modulation $\delta f_{1avg}$	140	165	175	kHz
6.2 Modulation $\delta f_{2max}$	115	130		kHz
6.3 Modulation $\delta f_{2avg}/\delta f_{1avg}$	0.8	0.88		
7. Carrier Frequency Drift				
7.1 1slot	-25		+25	kHz
7.2 3slot	-40		+40	kHz
7.3 5slot	-40		+40	kHz
7.4 Maximum drift rate	-20		+20	kHz/50us
8. Out-of-Band Spurious Emissions				
8.1 30-1000MHz (Operation Mode)		-58	-36	dBm
8.2 1000-12750MHz (Operation Mode)		-40	-30	dBm
8.3 1800-1900MHz(Operation Mode)		-80	-47	dBm
8.4 5150-5300MHz (Operation Mode)		-80	-47	dBm
9. EDR Relative Power (Pi/4-DQPSK and 8DPSK)	-4	-0.2	1	
10. EDR Carrier Frequency Stability and Modulation Accuracy				
10.1 $\omega_i$ (Pi/4-DQPSK and 8DPSK)	-75	0	75	kHz
10.2 $\omega_0$ (Pi/4-DQPSK and 8DPSK)	-10	0	10	kHz
10.3 $\omega_i+\omega_0$ (Pi/4-DQPSK and 8DPSK)	-75	0	75	kHz
10.4 RMS DEVM (Pi/4-DQPSK)		6	20	%
10.5 99% DEVM (Pi/4-DQPSK)		10	30	%
10.6 Peak DEVM (Pi/4-DQPSK)		14	35	%
10.7 RMS DEVM (8DPSK)		6	13	%



10.8 99% DEVM (8DPSK)		10	20	%
10.9 Peak DEVM (8DPSK)		16	25	%
RX characteristics				
11. Sensitivity (BER < 0.1%)				
11.1 2402MHz		-92	-70	dBm
11.2 2441MHz		-92	-70	dBm
11.3 2480MHz		-92	-70	dBm
12. C/I Performance (BER < 0.1%)				
12.1 co-channel ratio (-60dBm input)		8	11	dB
12.2 1MHz ratio (-60dBm input)		-10	0	dB
12.3 2MHz ratio (-60dBm input)		-38	-30	dB
12.4 3MHz ratio (-67dBm input)		-45	-40	dB
12.5 image +/- 1MHz ratio (-67dBm input)		-30	-20	dB
13. Blocking performance (BER < 0.1%)				
13.1 30MHz-2000MHz	-10	-8		dBm
13.2 2000MHz-2400MHz	-28	0		dBm
13.3 2500MHz-3000MHz	-28	0		dBm
13.4 3000MHz-12750MHz	-10	-5		dBm
14. Intermodulation performance (BER < 0.1%, -64dBm input)	-39	-30		dBm
15. Maximum Input Level	-20	-5		dBm
16. EDR Sensitivity (at 0.01% BER)				
16.1 Pi/4-DQPSK		-94	-70	dBm
16.2 8DPSK		-87	-70	dBm

**Table 45: Current consumption of Bluetooth**

Conditions	Min	Typ	Max	Unit
Search	16.4	38.3	107.6	mA
Matches	13.3	17.1	58.4	mA
Connect	17.5	24.1	74.8	mA

## 6.9 Electro-Static Discharge

SIM800H is an ESD sensitive component, so attention should be paid to the procedure of handling and packaging. The ESD test results are shown in the following table.

**Table 46: The ESD characteristics (Temperature: 25 °C, Humidity: 45 % )**

Pin name	Contact discharge	Air discharge
VBAT	±6KV	±12KV
GND	±6KV	±12KV
RXD, TXD	±2KV	±8KV
Antenna port	±5KV	±10KV
SPK_P/SPK_N/MIC_P/MIC_N	±2KV	±5KV
PWRKEY	±2KV	±8KV

## 6.10 Radio Characteristics

### 6.10.1. Module RF Output Power

The following table shows the module conducted output power, it is followed by the 3GPP TS 05.05 technical specification requirement.

**Table 47: GSM850 and EGSM900 conducted RF output power**

GSM850,EGSM900			
PCL	Nominal output power (dBm)	Tolerance (dB) for conditions	
		Normal	Extreme
5	33	±2	±2.5
6	31	±3	±4
7	29	±3	±4
8	27	±3	±4
9	25	±3	±4
10	23	±3	±4
11	21	±3	±4
12	19	±3	±4
13	17	±3	±4
14	15	±3	±4
15	13	±3	±4
16	11	±5	±6
17	9	±5	±6
18	7	±5	±6
19-31	5	±5	±6

**Table 48: DCS1800 and PCS1900 conducted RF output power**

DCS1800,PCS1900			
PCL	Nominal output power (dBm)	Tolerance (dB) for conditions	
		Normal	Extreme
0	30	±2	±2.5
1	28	±3	±4
2	26	±3	±4
3	24	±3	±4
4	22	±3	±4
5	20	±3	±4
6	18	±3	±4
7	16	±3	±4
8	14	±3	±4
9	12	±4	±5
10	10	±4	±5
11	8	±4	±5
12	6	±4	±5
13	4	±4	±5
14	2	±5	±6
15	0	±5	±6

### 6.10.2. Module RF Receive Sensitivity

The following table shows the module's conducted receiving sensitivity, it is tested under static condition.

**Table 49: Conducted RF receive sensitivity**

Frequency	Receive sensitivity (Typical)	Receive sensitivity(Max)
GSM850,EGSM900	< -108dBm	< -106dBm
DCS1800,PCS1900	< -108dBm	< -106dBm

### 6.10.3. Module Operating Frequencies

The following table shows the module's operating frequency range; it is followed by the 3GPP TS 05.05 technical specification requirement.

**Table 50: Operating frequencies**

Frequency	Receive	Transmit
GSM850	869 ~ 894MHz	824 ~ 849MHz
EGSM900	925 ~ 960MHz	880 ~ 915MHz
DCS1800	1805 ~ 1880MHz	1710 ~ 1785MHz
PCS1900	1930 ~ 1990MHz	1850 ~ 1910MHz

## 7. Manufacturing

### 7.1. Top and Bottom View of SIM800H

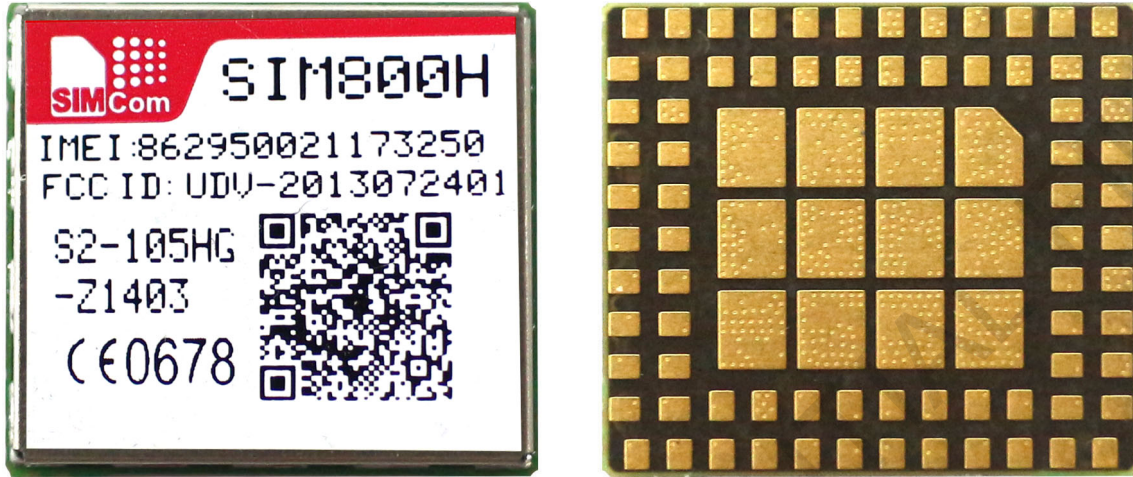


Figure 53: Top and bottom view of SIM800H

### 7.2. Typical Solder Reflow Profile

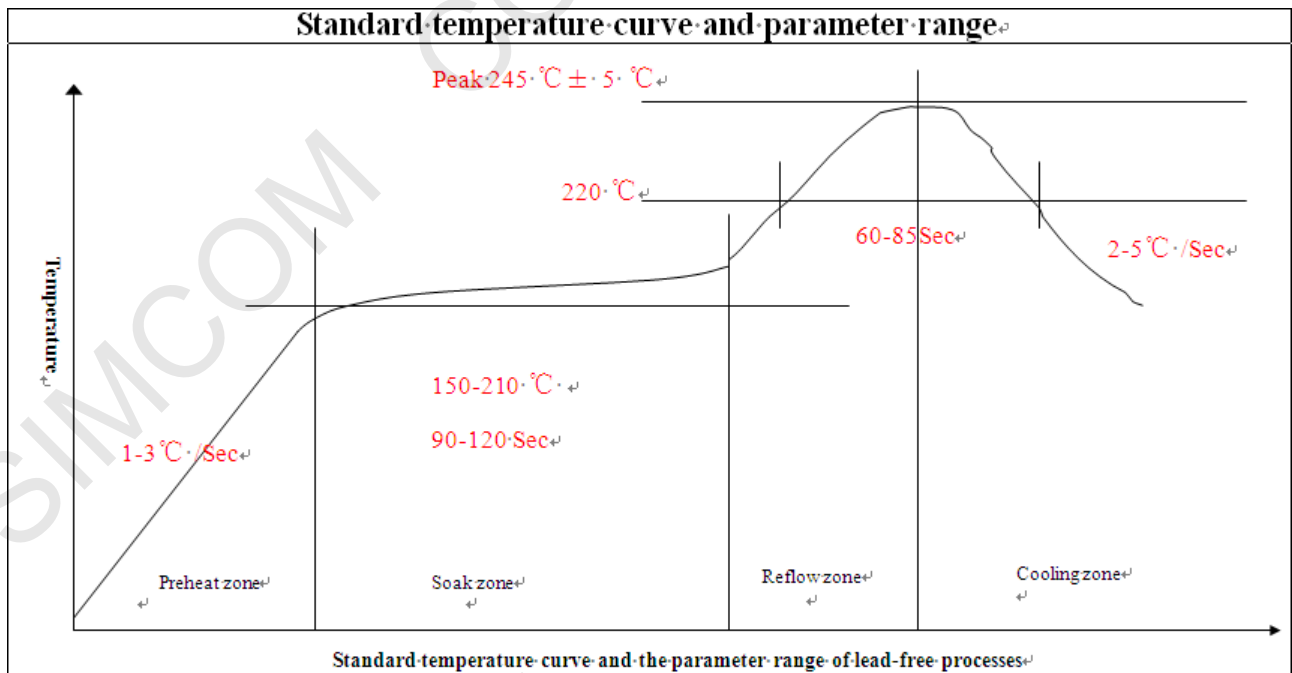


Figure 54: Typical solder reflow profile of lead-free processes

### 7.3. The Moisture Sensitivity Level

The moisture sensitivity level of SIM800H module is 3. The modules should be mounted within 168 hours after unpacking in the environmental conditions of temperature  $<30^{\circ}\text{C}$  and relative humidity  $<60\%$  necessary to bake the module if the above conditions are not met:

**Table 51: Moisture sensitivity level and floor life**

Moisture Sensitivity Level (MSL)	Floor Life (out of bag) at factory ambient $\leq 30^{\circ}\text{C}/60\%$ RH or as stated
1	Unlimited at $\leq 30^{\circ}\text{C}/85\%$ RH
2	1 year
2a	4 weeks
3	168 hours
4	72 hours
5	48 hours
5a	24 hours
6	Mandatory bake before use. After bake, it must be reflowed within the time limit specified on the label.

*Note: For product handling, storage, processing, IPC / JEDEC J-STD-033 must be followed.*

### 7.4. Baking Requirements

SIM800H modules are vacuum packaged, and guaranteed for 6 months storage without opening or leakage under the following conditions: the environment temperature is lower than  $40^{\circ}\text{C}$ , and the air humidity is  $<60\%$ .

If the condition meets one of the following ones shown below, the modules should be baked sufficiently before re-flow soldering, and the baking condition is shown in below table; otherwise the module will be at the risk of permanent damage during re-flow soldering.

- If the vacuum package is broken or leakage;
- If the vacuum package is opened after 6 months since it's been packed;
- If the vacuum package is opened within 6 months but out of its Floor Life at factory ambient  $\leq 30^{\circ}\text{C}/60\%$  RH or as stated

**Table 52: Baking requirements**

Baking temperature	Moisture	Time
$40^{\circ}\text{C} \pm 5^{\circ}\text{C}$	$<5\%$	192 hours
$120^{\circ}\text{C} \pm 5^{\circ}\text{C}$	$<5\%$	6 hours

*Note: Care should be taken if that plastic tray is not heat-resistant, the modules should be taken out for preheating, otherwise the tray may be damaged by high-temperature heating.*

## 8. Appendix

### I. Related Documents

**Table 53: Related documents**

SN	Document name	Remark
[1]	SIM800 Series AT Command Manual	
[2]	SIM800 Series UART Port Application Note_V1 01.doc	
[3]	ITU-T Draft new recommendation V.25ter	Serial asynchronous automatic dialing and control
[4]	GSM 07.07	Digital cellular telecommunications (Phase 2+); AT command set for GSM Mobile Equipment (ME)
[5]	GSM 07.10	Support GSM 07.10 multiplexing protocol
[6]	GSM 07.05	Digital cellular telecommunications (Phase 2+); Use of Data Terminal Equipment – Data Circuit terminating Equipment (DTE – DCE) interface for Short Message Service (SMS) and Cell Broadcast Service (CBS)
[7]	GSM 11.14	Digital cellular telecommunications system (Phase 2+); Specification of the SIM Application Toolkit for the Subscriber Identity Module – Mobile Equipment (SIM – ME) interface
[8]	GSM 11.11	Digital cellular telecommunications system (Phase 2+); Specification of the Subscriber Identity Module – Mobile Equipment (SIM – ME) interface
[9]	GSM 03.38	Digital cellular telecommunications system (Phase 2+); Alphabets and language-specific information
[10]	GSM 11.10	Digital cellular telecommunications system (Phase 2); Mobile Station (MS) conformance specification; Part 1: Conformance specification
[11]	AN_Serial Port	AN_Serial Port
[12]	Module secondary-SMT-UGD	Module secondary SMT User Guide
[13]	AN_SMT Module_RF_Reference Design_Guide	

## II. Terms and Abbreviations

**Table 54: Terms and abbreviations**

Abbreviation	Description
ADC	Analog-to-Digital Converter
AMR	Adaptive Multi-Rate
CS	Coding Scheme
CTS	Clear to Send
DTE	Data Terminal Equipment (typically computer, terminal, printer)
DTR	Data Terminal Ready
DTX	Discontinuous Transmission
EFR	Enhanced Full Rate
EGSM	Enhanced GSM
ESD	Electrostatic Discharge
ETS	European Telecommunication Standard
FR	Full Rate
GPRS	General Packet Radio Service
GSM	Global Standard for Mobile Communications
HR	Half Rate
IMEI	International Mobile Equipment Identity
Li-ion	Lithium-Ion
MO	Mobile Originated
MS	Mobile Station (GSM engine), also referred to as TE
MT	Mobile Terminated
PAP	Password Authentication Protocol
PBCCH	Packet Broadcast Control Channel
PCB	Printed Circuit Board
PCL	Power Control Level
PCS	Personal Communication System, also referred to as GSM 1900
PDU	Protocol Data Unit
PPP	Point-to-point protocol
RF	Radio Frequency
RMS	Root Mean Square (value)
RTC	Real Time Clock
RX	Receive Direction
SIM	Subscriber Identification Module
SMS	Short Message Service
TE	Terminal Equipment, also referred to as DTE
TX	Transmit Direction
UART	Universal Asynchronous Receiver & Transmitter
URC	Unsolicited Result Code







USSD	Unstructured Supplementary Service Data
<b>Phonebook abbreviations</b>	
FD	SIM fix dialing phonebook
LD	SIM last dialing phonebook (list of numbers most recently dialed)
MC	Mobile Equipment list of unanswered MT calls (missed calls)
ON	SIM (or ME) own numbers (MSISDNs) list
RC	Mobile Equipment list of received calls
SM	SIM phonebook
NC	Not connect

SIMCOM CONFIDENTIAL FILE



### III. Safety Caution

**Table 55: Safety caution**

Marks	Requirements
	<p>When in a hospital or other health care facility, observe the restrictions about the use of mobiles. Switch the cellular terminal or mobile off, medical equipment may be sensitive to not operate normally for RF energy interference.</p>
	<p>Switch off the cellular terminal or mobile before boarding an aircraft. Make sure it is switched off. The operation of wireless appliances in an aircraft is forbidden to prevent interference with communication systems. Forget to think much of these instructions may lead to the flight safety or offend against local legal action, or both.</p>
	<p>Do not operate the cellular terminal or mobile in the presence of flammable gases or fumes. Switch off the cellular terminal when you are near petrol stations, fuel depots, chemical plants or where blasting operations are in progress. Operation of any electrical equipment in potentially explosive atmospheres can constitute a safety hazard.</p>
	<p>Your cellular terminal or mobile receives and transmits radio frequency energy while switched on. RF interference can occur if it is used close to TV sets, radios, computers or other electric equipment.</p>
	<p>Road safety comes first! Do not use a hand-held cellular terminal or mobile when driving a vehicle, unless it is securely mounted in a holder for hands free operation. Before making a call with a hand-held terminal or mobile, park the vehicle.</p>
	<p>GSM cellular terminals or mobiles operate over radio frequency signals and cellular networks and cannot be guaranteed to connect in all conditions, for example no mobile fee or a invalid SIM card. While you are in this condition and need emergent help, please remember using emergency calls. In order to make or receive calls, the cellular terminal or mobile must be switched on and in a service area with adequate cellular signal strength.</p> <p>Some networks do not allow for emergency call if certain network services or phone features are in use (e.g. lock functions, fixed dialing etc.). You may have to deactivate those features before you can make an emergency call.</p> <p>Also, some networks require that a valid SIM card be properly inserted in the cellular terminal or mobile.</p>

**Contact us:**

**Shanghai SIMCom Wireless Solutions Co.,Ltd.**

Address: Building A, SIM Technology Building, No. 633, Jinzhong Road, Shanghai, P. R. China  
200335

Tel: 86-21-32523300

Fax: 86-21-32523020

Email: [simcom@sim.com](mailto:simcom@sim.com)

Website: [www.simcomm2m.com](http://www.simcomm2m.com)

SIMCOM CONFIDENTIAL FILE